

# RG1

Edition February 2024  
Right reserved to effect techn. modifications  
in the interest of product improvement.

**Gas**



---

## Contents

Overview .....	3
General information / safety information .....	3
Checking scope of delivery and connection data.....	3
Operating instructions .....	4
Instruction of operating personnel.....	4
Maintenance and customer service .....	4
Key for code designation .....	4
Technical specifications .....	4
Installation .....	5
Installing flange and burner.....	5
Installing gas assembly.....	5
Service position.....	5
Dimensions for checking the mixer unit .....	5
Establishing electrical connections .....	6
Function .....	7
Control box LME .....	7
Air flow setting, measurement "A" .....	10
Air flap positioning motor .....	10
Compact gas unit.....	11
Adjustable gas pressure switch (only on version KE 15) .....	11
Start-up .....	12
Adjustment tables .....	12
Adjusting gas burner and boiler .....	13
Calculation principle for gas burner adjustment.....	15
Design .....	17
Exploded view and parts list .....	17
Service instructions/dimensions .....	18
Flame control with ionization control.....	18
Measurement of the ionization current LME control unit.....	18
Servicing air pressure monitor .....	18
Wiring diagram.....	19
Declaration of conformity .....	20
Burner overall dimensions / boiler connection dimensions .....	22
Working ranges.....	22

# Overview

## General information / safety information

The installation of a gas-fired system must conform to extensive regulations and requirements. It is therefore the duty of the installer to be familiar with all applicable regulations and requirements. Installation, start-up and maintenance must be performed with utmost care.

The burner must not be operated in rooms with high levels of air humidity (laundry rooms), dust or corrosive vapours. The boiler room must be ventilated accordingly with ventilation air.

The GIERSCH RG1 series gas burners are suitable for burning natural gas or liquefied petroleum gas and comply with the European standard DIN EN 676.

**Caution !**

**Improper installation, adjustment, modification, operation or maintenance may result in physical injury or damage to property/equipment.**

**Read the instructions prior to use.**

**This product must be installed in accordance with the valid regulations (e.g. DIN-VDE, DIN-DVGW).**

The design and degree of protection of the burner make it suitable for operation in enclosed rooms.

## Checking scope of delivery and connection data

Before installing the GIERSCH gas burner, please check that all items included in the scope of delivery are present.

Scope of delivery:

Burner, sliding flange and gasket, 4 retaining screws, separate operating instructions, technical information, one 7-pin connector.

Compact gas unit and gasket (see Overview, Page 9).

The gas pipe must be designed to conform to the flow rate and the available gas flow pressure and routed with the lowest pressure loss over the shortest distance to the burner. The loss of gas pressure via the compact unit and the burner and the resistance on the fuel gas side of the heat generator must be less than the connection flow pressure.

**Caution !**

**Observe throughflow direction of compact unit.**

## Operating instructions

The operating instructions together with this technical information leaflet must be displayed in a clearly visible position in the boiler room. It is essential to write the address of the nearest customer service centre in the operating instructions.

## Instruction of operating personnel

Faults are often caused by operator error. The operating personnel must be properly instructed in how the burner works. In the event of recurring faults, Customer Service should be notified.

## Maintenance and customer service

The complete system should be checked once a year for correct functioning and leaks by a representative of the manufacturer or other suitably qualified person.

We accept no liability for consequential damage in cases of incorrect installation or repair, the fitting of non-genuine parts or where the equipment has been used for purposes for which it was not intended.

## Key for code designation

### RG 1-L-N(F)

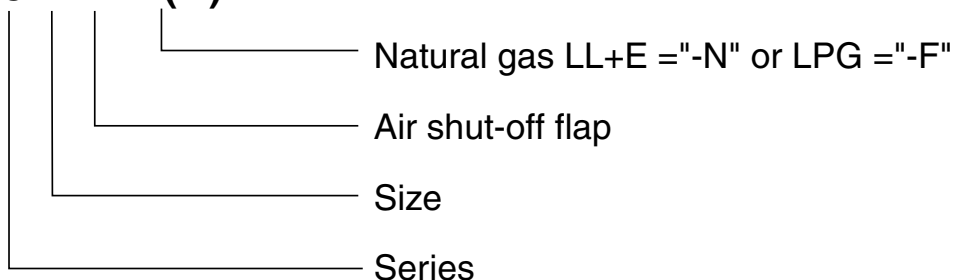

## Technical specifications

Technical data	Burner type			
	RG1(-L)-Na	RG1(-L)-Nb	RG1(-L)-Fa	RG1(-L)-Fb
Min. burner output in kW	12	25	15	25
Max. burner output in kW	40	61	40	61
Min. boiler output in kW	11	23	14	23
Max. boiler output in kW	37	56	37	56
Gas type	for natural gas LL + E = "-N" / for LPG 3B/P = "-F"			
Max. gas pressure in mbar	70			
Voltage	1/N/PE ~50 Hz - 230 V			
Current consumption start max. / operation	1.9 A / 0.8 A			
Electric motor power in W	90			
ignition transformer	1x8 kV / 20 mA			
Control box	LME 11			
Weight in kg	14			
Noise emission in dB(A)	≤ 59			
Emission class	2			
NOx limit value	80 - 120 mg/kWh			

## Installation

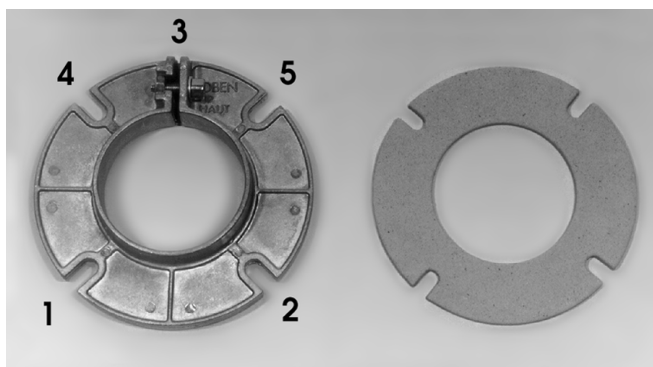

Installation position KE

### Installing flange and burner

When installing the sliding flange, only tighten screws 1 and 2 otherwise it will not be possible to secure the burner pipe with screw 3. Slide in the burner, adjust to furnace depth and tighten the screws in the following sequence: 3, 4, 5, raising the housing in the process.

**Important:** Secure the sliding flange so that the clamping screw 3 is positioned at the top.

### Installing gas assembly

- Remove plastic protective plug.
- Install unions including accompanying seals.
- Observe installation position.
- Check connecting point of gas assembly with non-corrosive foaming agent for leaks and vent gas pipe.
- When venting gas, discharge safely to atmosphere with a hose.

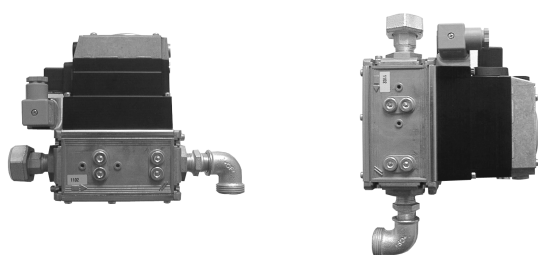

Comply with DVGW-TRGI 1986/96 Section 7, TRF 1988, DIN 4756 and local regulations.

### Service position



**Risk of injury by fan wheel during activation in service position.**

- Release quick-release locks and detach base plate.
- Suspend base plate with retaining buttons in cross recesses of housing.

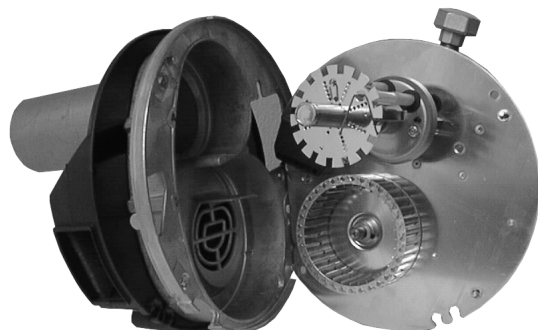

### Dimensions for checking the mixer unit

The ignition electrodes are preset at the factory. The dimensions are specified for checking purposes.

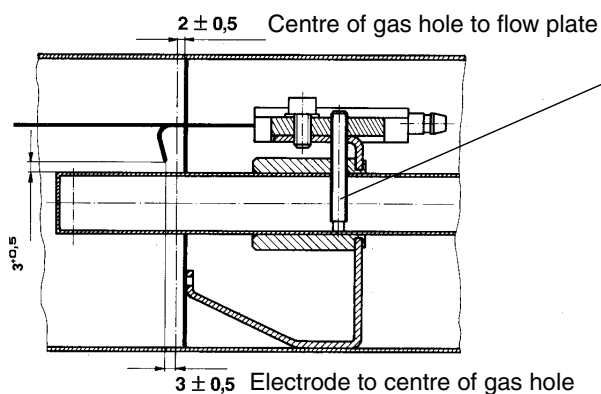

**Caution:**

Grubscrew determines the position of the holder and fully tightened. There is still slight play at the holder.

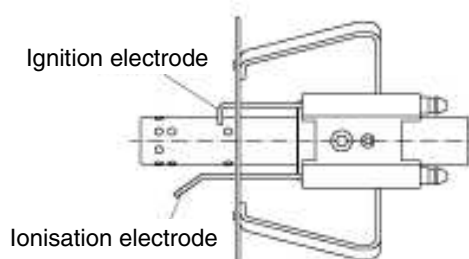

## Establishing electrical connections

- Disconnect system from power supply. Main switch "OFF".
- Check polarity of all connectors.
- Wire connector unit in accordance with connection diagram. Lay flexible control line so that boiler door can still be swivelled.
- Attach cube connector to gas-pressure monitor connector A (grey) and to solenoid valves B (black) and secure with screw.
- Check correct wiring of wired connector unit X11 according to connection diagram.
- Attach 7-pin connector unit for boiler control (X11) to black-brown socket unit on burner (X12).
- Supply lead to 7-pin connector unit X11 must be protected with a min. 6.3 A slow-blowing or max. 10 A quick-blowing fuse.

## Connection diagram

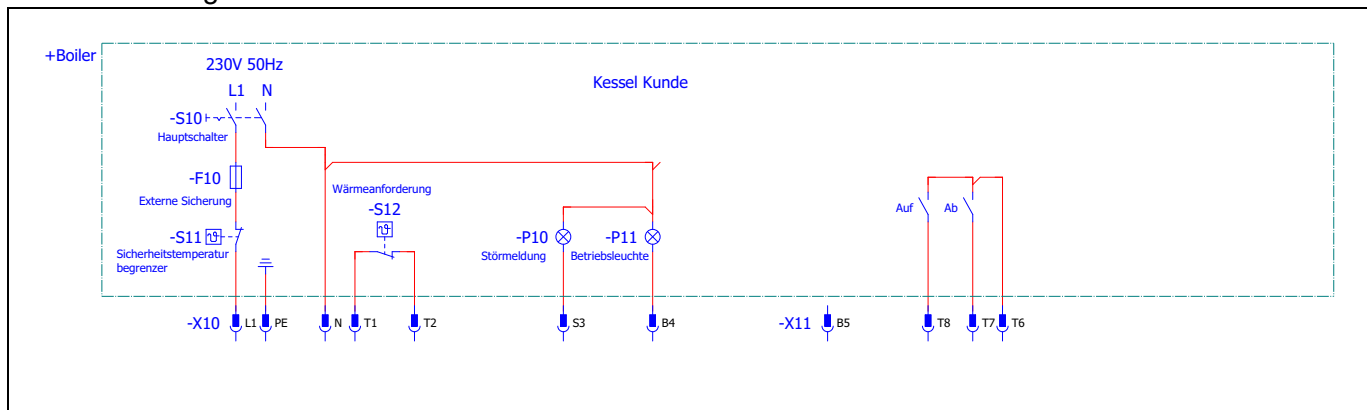

## Function



### Control unit LME

Testing the control unit for proper functioning  
 Danger of fatal injury from electric shocks!



Disconnect electrical cable from power supply before carrying out any work on live parts! Troubleshooting may only be carried out by authorised and trained personnel! Unlocking may only be carried out by an authorised specialist.

**After startup and after maintenance of the burner, the following controls to perform.**

Burner startup with broken lines to the flame detector:

- Disconnect the cable to the flame monitor and restart the burner.  
At the end of the safety time the controller makes a lockout
- Reestablish the connection.

Burner operation with simulated loss of flame:

- Pull the compact unit the square plug from the gas pressure switch and jumper the contacts in the connector.
- Start the burner.
- Connect operation are the ball valve.  
After loss of flame, the controller makes a lockout.
- Remove the jumper in the connector and insert it back to the gas pressure switch of the compact unit.

Burner operation with simulated air pressure loss:

- Pull are the operation from the air hose to the "+" input of the air pressure switch.  
The controller makes a lockout.
- Insert the air hose back onto the air pressure switch

### Safety and switching functions

In the event of a flame failure during operation, the fuel supply is immediately switched off and the control box goes into fault mode. A restart takes place in all cases following a mains power failure. A fault is triggered immediately if there is flame detection during pre-ventilation. The position of the air pressure monitor is continuously checked. There can be no start-up if it is not in its neutral position. A fault is triggered if the working contact fails to close during pre-ventilation, or reopens. In the event of a lack of air during operation, the air pressure monitor contact opens and the valves close immediately. The device goes into fault mode.

**Operational status indication**

Color code table for multicolor signal lamp (LED)		
Status	Colore code	Color
Waiting time «tw», other waiting states	○.....	OFF
Oil preheater on	●.....	Yellow
Ignition phase, ignition controlled	○●○●○●○●○●	Flashing yellow
Operation, flame o.k.	■.....	Green
Operation, flame not o.k.	○■○■○■○■○■	Flashing green
Extraneous light on burner startup	■▲■▲■▲■▲■▲	Green-red
Undervoltage	●▲●▲●▲●▲●	Yellow-red
Fault, alarm	▲.....	Red
Error code output (refer to «Error code table»)	○▲○▲○▲○▲○▲○	Flashing red
Interface diagnostics	▲▲▲▲▲▲▲▲▲▲▲▲▲▲	Red flicker light

Legend:

- ..... Steady on
- OFF
- ▲ Red
- Yellow
- Green



### Diagnostics of the cause of fault

After lockout, the red signal lamp will remain steady on. In that condition, visual diagnostics of the cause of fault according to the error code table can be activated by pressing the lockout reset button for more than 3 seconds. Pressing the lockout reset button again for at least 3 seconds, interface diagnostics will be activated. Interface diagnostics works only if the lockout reset button extension AGK20... is not fitted. If, by accident, interface diagnostics has been activated, in which case the slightly red light of the signal lamp flickers, it can be deactivated by pressing again the lockout reset button for at least 3 seconds. The instant of switching over is indicated by a yellow light pulse.

### Error code table

Red blink code of signal lamp (LED)	Alarm at term. 10	Possible cause
2 x blinks	ON	No establishment of flame at the end of safety time - Faulty or soiled fuel valves - Faulty or soiled flame detector - Poor adjustment of burner, no fuel - Faulty ignition equipment
3 x blinks	ON	Air pressure switch faulty - Loss of air pressure signal after specified time - Air pressure switch welded in normal position
4 x blinks	ON	Extraneous light when burner is started up
5 x blinks	ON	Air pressure switch time supervision - Air pressure switch welded in working position - Error with valve proving (only in conjunction with LDU11...)
6 x blinks	ON	Free
7 x blinks	ON	Too many losses of flame during operation (limitation of repetitions) - Faulty or soiled fuel valves - Faulty or soiled flame detector - Poor adjustment of burner
8 x blinks	ON	Free
9 x blinks	ON	Free
10 x blinks	OFF	Wiring error or internal error, output contacts, other faults
14 x blinks	ON	CPI contact not closed

During the time the cause of fault is diagnosed, the control outputs are deactivated

- Burner remains shut down
- External fault indication remains deactivated
- Fault status signal (alarm) at terminal 10, according to the error code table

The diagnostics of the cause of fault is quit and the burner switched on again by resetting the burner control. Press the lockout reset button for about 1 second (<3 seconds).

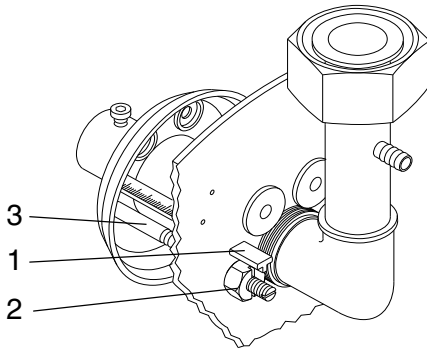

### Air flow setting, measurement "A"

1. Distance "A"
2. Locknut for air-restrictor setting

Turn screw (3) clockwise: **Air -**

Turn screw (3) anticlockwise: **Air +**

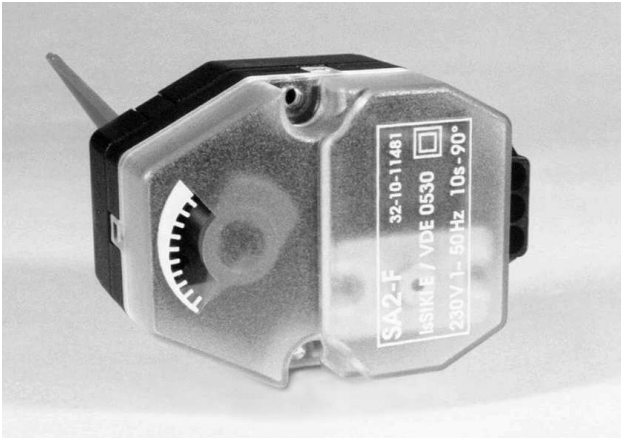

### Air flap positioning motor (-L type)

Cooling of furnace avoided during burner standstill.

#### SA2-F:

Position "OPEN" - "CLOSED" of electric-motor-driven unit indicated at display lever. When servicing/retrofitting, refer to wiring diagram on Page 17.



Do not turn red positioning lever by hand as mechanism is destructible.

## Compact gas unit

The compact gas units for GIERSCH gas burners are preassembled and checked for leaks.

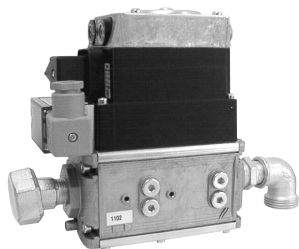

### Version KE 15:

1-stage precision pressure regulator with high control quality and adjustable starting gas pressure.



### Version KE 10:

1-stage precision pressure controller with high control quality and adjustable start gas pressure.

The compact gas unit KE 10 is provided with a non-adjustable gas pressure switch (switching point 12 mbar falling).

## Technical data of compact gas unit

Gas types:	Natural gas, propane and butane, acc. to DIN EN 437/DIN EN 88
Inlet pressure:	max. 360 (KE 15), max. 70 mbar (KE 10) min. 18 mbar
Max. pressure drop:	50 mbar (supply pressure - output pressure)
Ambient temperature:	-10 °C to +60 °C
Connecting flanges:	The connecting flanges are secured with 4 screws. The flanges can be turned through 90° or 180° in each case. Pressure measuring points in inlet and in outlet.
Filter:	Nylon wire gauze with chopped-strands mat fleece
Solenoid valves (T. A):	
Closing time:	< 1 s
Switching frequency:	any
Duty factor:	100% DF
Degree of protection:	IP 54 to IEC 529

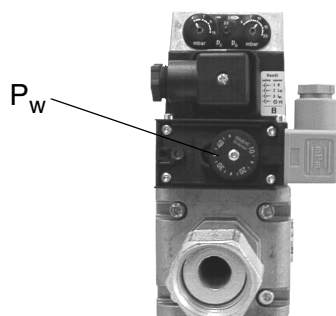

## Adjustable gas pressure switch

(only on version KE 15)

The gas pressure monitor serves to monitor the gas inlet pressure. The burner is shut down if the gas inlet pressure drops below the set minimum value (preset at factory to 12 mbar). The burner starts up automatically when the minimum pressure is exceeded.

This setting should be retained.

## Start-up



The values given in the tables are only setting values for start-up. The system settings required in each case must be redefined if values such as boiler output, calorific value and altitude deviate. **A correction is required in any case.**

### Adjustment tables: RG1-Na

Burner output [kW]	Boiler output at $\eta = 92\%$ [kW]	Gas type	Natural gas E: $H_{i,n} = 10.4$ [kWh/m <sup>3</sup> ]		Air flow measurement "A" [mm]
			Gas nozzle pressure [mbar]	Gas flow [m <sup>3</sup> /h]	
14.1	13	E	1.4	1.4	6 - 7
17.4	16	E	2.1	1.8	8 - 9
23.9	22	E	3.8	2.4	9 - 11
28.3	26	E	5.5	2.9	11 - 12
34.8	32	E	8.0	3.6	12 - 13
40.2	37	E	11	4.1	12 - 15

Burner output [kW]	Boiler output at $\eta = 92\%$ [kW]	Gas type	Natural gas LL: $H_{i,n} = 9.3$ [kWh/m <sup>3</sup> ]		Air flow measurement "A" [mm]
			Gas nozzle pressure [mbar]	Gas flow [m <sup>3</sup> /h]	
14.1	13	LL	1.8	1.6	6 - 7
17.4	16	LL	2.6	2.0	8 - 9
23.9	22	LL	4.8	2.7	9 - 11
28.3	26	LL	7.0	3.2	11 - 12
34.8	32	LL	10.4	4.0	12 - 13
40.2	37	LL	14.0	4.6	12 - 15

### RG1-Fa

Burner output [kW]	Boiler output at $\eta = 92\%$ [kW]	LPG 3B/P: $H_{i,n} = 25.8$ [kWh/m <sup>3</sup> ]		Air flow measurement "A" [mm]
		Gas nozzle pressure [mbar]	Gas flow [m <sup>3</sup> /h]	
15.0	14	2.4	0.6	6 - 7
17.4	16	3.0	0.7	8 - 9
22.2	20	5.8	0.9	9 - 10
27.8	26	9.0	1.1	11 - 12
33.3	31	12.3	1.4	11 - 13
40.2	37	15.5	1.6	12 - 15

### RG1-Nb

Burner output [kW]	Boiler output at $\eta = 92\%$ [kW]	Gas type	Natural gas E: $H_{i,n} = 10.4$ [kWh/m <sup>3</sup> ]		Air flow measurement "A" [mm]
			Gas nozzle pressure [mbar]	Gas flow [m <sup>3</sup> /h]	
25.0	23	E	1.7	2.5	10 - 11
33.7	31	E	3.0	3.4	11 - 12
39.1	36	E	4.3	3.9	12 - 13
44.6	41	E	5.4	4.5	13 - 15
50.0	46	E	6.8	5.1	15 - 18
58.7	54	E	9.2	6.0	20 - 26

## RG1-Nb

Burner output [kW]	Boiler output at $\eta = 92\%$ [kW]	Gas type	Natural gas LL: $H_{i,n} = 9.3$ [kWh/m <sup>3</sup> ]		Air flow measurement "A" [mm]
			Gas nozzle pressure [mbar]	Gas flow [m <sup>3</sup> /h]	
25.0	23	LL	2.1	2.9	10 - 11
33.7	31	LL	3.8	3.9	11 - 12
39.1	36	LL	5.5	4.5	12 - 13
44.6	41	LL	6.8	5.1	13 - 15
50.0	46	LL	8.7	5.7	15 - 18
58.7	54	LL	11.7	6.7	20 - 26

## RG1-Fb

Burner output [kW]	Boiler output at $\eta = 92\%$ [kW]	LPG 3B/P: $H_{i,n} = 25.8$ [kWh/m <sup>3</sup> ]		Air flow measurement "A" [mm]
		Gas nozzle pressure [mbar]	Gas flow [m <sup>3</sup> /h]	
25	23	2.8	1.0	10 - 11
33.7	31	5.3	1.4	11 - 12
39.1	36	7.2	1.6	12 - 13
44.6	41	9.0	1.8	13 - 15
50.0	46	11.0	2.1	15 - 18
58.7	54	14.0	2.4	20 - 26

## Adjusting gas burner and boiler

The burner can be put into operation once the installation and assembly work has been completed.

- Measure inlet pressure with U-pipe pressure gauge at measuring point "A".  
max. 360 mbar (KE 15), max. 70 mbar (KE 10, static pressure)  
min. 18 mbar (flow pressure) on RG1...-N  
min. 35 mbar (flow pressure) on RG1-F
- Burner and gas assembly are preset at factory to low output. This enables a soft burner start-up.
- Adjusting the burner to the desired nominal output in accordance with the adjustment tables on Pages 10, 11.

### To do so:

- Check gas working pressure with U-pipe pressure gauge at measuring point "B" outlet pressure.



#### Caution !

**Minimum pressure difference (inlet-outlet pressure) 5 mbar!**

- Adjust gas pressure and air flow measurement "A" according to adjustment tables, PP. 10, 11.
- Check exhaust gas values here without fail (CO, CO<sub>2</sub> or O<sub>2</sub>).

Exhaust gas values	Natural gas LL+E	LPG propane 3B/P
O <sub>2</sub> content	3.5-5.0%	
CO <sub>2</sub> content	9-10%	11-12%

- Depending on the system, the setting values must be corrected.
- After completion of adjustment, check the setting data.
- Check the gas pressure monitor after start-up. To do so, close ball valve slowly; burner must shut down but not go into fault mode.

Single-stage gas burner with compact units:

Installation of compact unit	
Installation position, vertical line:	as desired
Installation position, horizontal line:	tilted up to max. 90° to left or right, not over head
Minimum distance to walling:	20 mm

KE 10

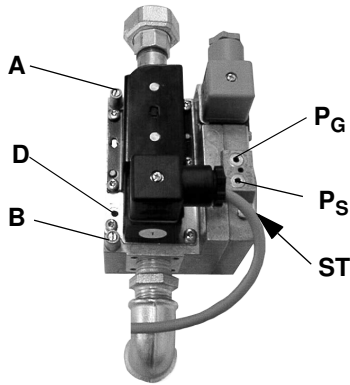

Gas supply pressure measuring point **A** ( $P_{inlet}$ )

Gas nozzle pressure measuring point **B** ( $P_{outlet}$ )

$p_S$  = starting gas pressure

$p_G$  = main gas pressure

$p_W$  = switching point of gas pressure switch

$p_L$  = screw cap starting gas pressure

**ST** = screw cap

**D** = gas volume adjustment (only on KE 10)

Dimension "A" = adjust in accordance with specifications in the air volume adjustment table (see Fig. p. 8)

KE 15

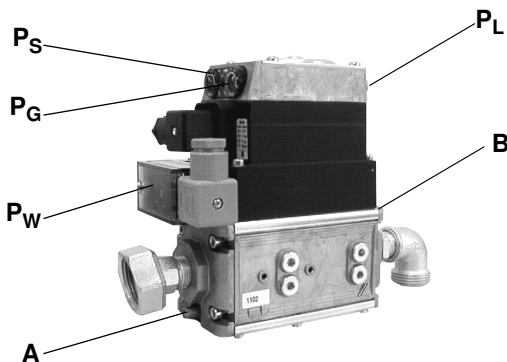

**Presetting (only on KE 15):**

Locate relevant line of adjustment table according to boiler output and adopt setting values.

- Adjust dimension "A" according to specifications of adjustment table.

**Gas nozzle pressure  $\leq 5$  mbar:**

- $P_G$ : adjust main gas pressure on min.
- $P_S$ : adjust starting gas pressure according to the specifications of the adjustment tables.

**Gas nozzle pressure  $> 5$  mbar:**

- $P_G$ : adjust main gas pressure according to the specifications of the adjustment tables.
- $P_S$ : starting gas pressure to approx. 40-60% of main gas pressure, min. 4 mbar.

**Precision adjustment KE 10:**

- Measure gas nozzle pressure at measuring point **B**.
- Increase main gas pressure via gas volume throttle **D** in direction "+" ("-" decrease). Adjusting range approx. 3 - 14 mbar.
- Adapt dimension "A" air volume adjustment (see adjustment tables pp. 10-11).
- If gas nozzle pressures are less than 3 mbar, turn the gas volume throttle **D** in direction "-" until approx. 3 mbar is reached.
- Turn adjusting screw  $P_G$  in direction "-" and reduce the nozzle pressure.
- Only if gas nozzle pressures are greater than 14 mbar:  
Turn gas volume throttle **D** in direction "+" up to the stop. For further procedure see precision adjustment KE 15.

**Precision adjustment on KE 15:**

- At measuring point **B** measure gas nozzle pressure.

**Gas nozzle pressure  $\leq 5\text{mbar}$ :**

- Start burner; if there is no flame formation, check adjustment.
- After approx. 10 sec. correct starting gas pressure  $p_s$  according to adjustment table.

Air setting measurement "A"	Exhaust gas values	
Reduce if:	CO <sub>2</sub> too low	O <sub>2</sub> too high
Increase if:	CO <sub>2</sub> too high	O <sub>2</sub> too low

**Gas nozzle pressure  $> 5\text{mbar}$ :**

- Start burner, if there is no flame formation, check adjustment. If necessary adjust starting gas pressure  $P_s$  higher (attention: always adjust  $P_s \leq P_G$ )
- After approx. 10 sec re-adjust main gas pressure  $P_G$  according to adjustment table.
- Then adapt dimension "A" air flow setting (see table). Secure air setting with lock nut.
- Perform an exhaust gas analysis, paying special attention to the CO emission.
- Seal off all measuring points.

**Calculation principle for gas burner adjustment**

The values given in the tables are setting values for start-up.

The necessary system adjustment must be newly determined in each case.

**General:**

The calorific value ( $H_{i,n}$ ) of fuel gasses is usually given for normal atmospheric conditions (0°C, 1013 mbar).

Natural gas type E  $H_{i,n} = 10.4 \text{ kWh/m}^3$

Natural gas type LL  $H_{i,n} = 9.3 \text{ kWh/m}^3$

Gas counters measure the volume of gas in the operational state.

**Specifying throughput:**

To allow correct setting of the heat generator load, the gas throughput must be determined in advance.

**Example:**

Height above sea level	230 m
Atmospheric pressure B (according to table)	989 mbar
Gas pressure $P_G$ at counter	20 mbar
Gas temperature $\vartheta_G$	16°C
Boiler rating $Q_n$	100 kW
Efficiency $\eta_K$ (assumed)	92%
Calorific value $H_{i,n}$	10.4 kWh/m <sup>3</sup>

**Gas flow in standard state ( $V_n$ )**

$$V_n = \frac{Q_n}{\eta_K \times H_{i,n}} = \frac{30 \text{ kW}}{0,92 \times 10,4 \frac{\text{kWh}}{\text{m}^3}} = 3,1 \frac{\text{m}^3}{\text{h}}$$

## Start-up

### Gas flow in operating state ( $V_B$ )

$$V_B = \frac{V_n}{f} = \frac{3,1 \frac{m^3}{h}}{0,94} = 3,3 \frac{m^3}{h}$$

### Conversion factor (f)

$$f = \frac{B + P_G}{1013} \times \frac{273}{273 + \vartheta_G}$$

### Annual average air pressure

Mean geodesic height of supplied region ASL [m]	from to	0	1 50	51 100	101 150	151 200	201 250	251 300	301 350	351 400	401 450	451 500	501 550	551 600	601 650	651 700	701 750
Annual average of air pressure	(mbar)	1016	1013	1007	1001	995	989	983	977	971	965	959	953	947	942	936	930

#### Key:

$Q_n =$	boiler rating [kW]
$\eta_K =$	efficiency [%]
$H_{i,n} =$	lower standard calorific value [kWh/m <sup>3</sup> ]
$f =$	conversion factor
$B =$	barometric pressure [mbar]
$p_G =$	gas pressure at gas counter [mbar]
$\vartheta_G =$	gas temperature at gas counter [°C]

### Flow measurement

Determining flow duration at gas meter.

Calculated flow duration in seconds  $t_{spec}$  for a flow volume of 200 litres (corresponding to 0.2 m<sup>3</sup>) for the example given above is:

$$V_B = 3,3 \frac{m^3}{h}$$

$$t_{soll} = \frac{0,2 m^3 \times 3600 \frac{s}{h}}{V_B \left[ \frac{m^3}{h} \right]} = \frac{720 m^3 \frac{s}{h}}{V_B \left[ \frac{m^3}{h} \right]} = \frac{720 m^3 \frac{s}{h}}{3,3 \frac{m^3}{h}} = 218s$$

### Gas flow setting

Measured flow duration in seconds [s]	Measures
Greater than calculated flow duration $t_{spec}$	Increase gas flow
Less than calculated flow duration $t_{spec}$	Reduce gas flow
Equal to calculated flow duration $t_{spec}$	Gas flow achieved



# Design

## Exploded view and parts list

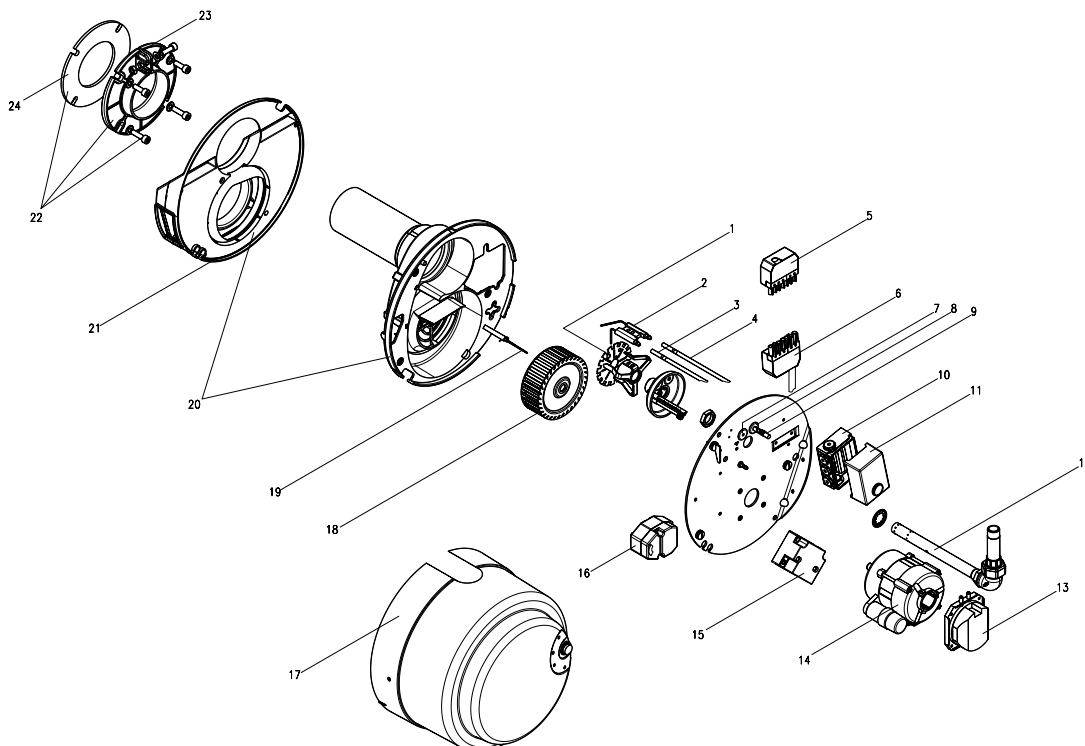

ZBZ\_1-536

Seq. No.	Designation	PU	Order No.
1	Flow plate with combination electrode for -N	1	34-90-10165
1	Flow plate with combination electrode for -F	1	34-390-10166
2	Combination electrode	5	37-50-20644
3	Replacement set Ionisation cable and Ignition cable	1	47-90-28005
5	Connector unit, 7-pin, green	5	37-50-11015
6	Socket unit 7-pin black-brown	5	37-50-20731
7	Cable gland G4 for ignition cable	20	37-50-11971
8	Cable gland G6 for ionisation cable	20	47-50-10890
10	Lower section, control box	1	37-90-11310-01
11	Control box LME 11	1	47-90-29190
12	Gas nozzle without flow plate for RG1-Na	1	34-90-10161
12	Gas nozzle without flow plate for RG1-Nb	1	34-90-10162
12	Gas nozzle without flow plate for RG1-Fa	1	34-90-10163
12	Gas nozzle without flow plate for RG1-Fb	1	34-90-10164
13	Air pressure monitor DL2E	1	47-90-29266
14	Motor 230 V/50 Hz 90 W with cable	1	31-90-11582
15	Ignition transformer mod. 26/35	1	47-90-24469
16	Positioning drive SA2-F with cable	1	57-90-11592
17	Burner cover	1	34-90-10146
18	Fan ø 120 x 42 mm	1	31-90-10106
19	Air flap assembly (plastic)	5	37-50-20971
20	Housing w. burner pipe (as of 4/91) and intake silencer	1	34-90-10967
21	Intake silencer	1	31-90-21660
22	Assembly unit	1	31-90-11421
24	Flange gasket	5	31-50-10104
-	Tightness control TC	1	34-20-40626
-	Compact unit CG10	1	47-90-21758
-	Compact unit CG15 without TC	1	47-90-22589
-	Compact unit CG15 with TC	1	47-90-22728
-	Gasket for gas union R 1/2"	10	37-50-20108
-	Ball valve 1/2"	1	34-20-40601
-	Filter mat for KE 1/2"	1	59-90-50466
-	Replacement set of quick release fasteners R R1 / R20 / RG1 / RG20	1	47-90-29351

## Service instructions/dimensions

### Flame control with ionization control

If an alternating voltage is applied between the burner and the ionizing bar, a direct current flows using the rectifying effect of the flame. This ionization current forms the flame signal and is sent amplified to the control unit. A flame cannot be simulated because the rectifier effect no longer works if there is a short circuit between the sensor electrode and the burner.

### Measurement of the ionization current

#### LME control unit

During commissioning and maintenance of the burner or after a fault message from the control unit, the measure ionization current. To do this, the plug connection in the ionization cable is disconnected and a measuring device for current measurement is connected in series. Measuring range 0...200  $\mu\text{A}$  DC. The measurement must be carried out directly after the post-ignition time during the safety time! The ionization current must be at least 5  $\mu\text{A}$ . Values below 5  $\mu\text{A}$  lead to unsafe operation (fault lamp flashes green) or directly to a fault. In this case, the inside of the ionizing bar and the burner tube must be cleaned. Bend the ionizing bar if necessary. If the ionizing bar is defective, replace the electrode. Possibly reverse the polarity of the ignition transformer. Check cable for moisture and dry if necessary.

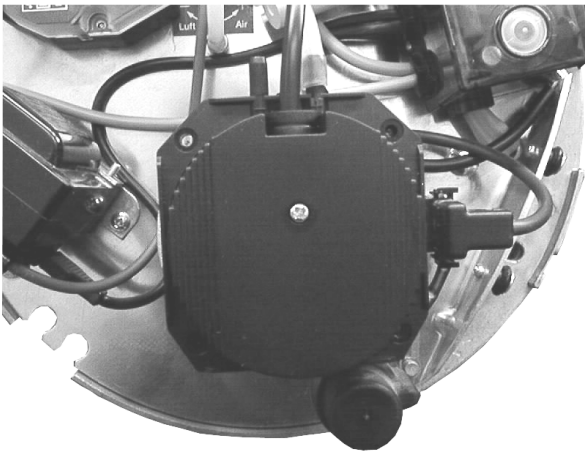

### Servicing air pressure monitor

- Detach silicone connecting hose and clean, check switching function.
- Replace air pressure monitor if switching function is no longer O.K.

#### To do so:

- Disconnect burner from power supply (pull 7-pin connector X12).
- Screw off cover.
- Disconnect electrical connectors.
- Release retaining screws on motor.
- Reassemble in reverse order.



„+“ denotes the connecting point for pressure measurement!

SP\_1-1051.2

Aderfarben	
Braun	- BN
Blau	- BU
Grau	- GY
Schwarz	- BK
Rot	- RD
Weiss	- WH
Grünelb	- GNYE
Violett	- VT

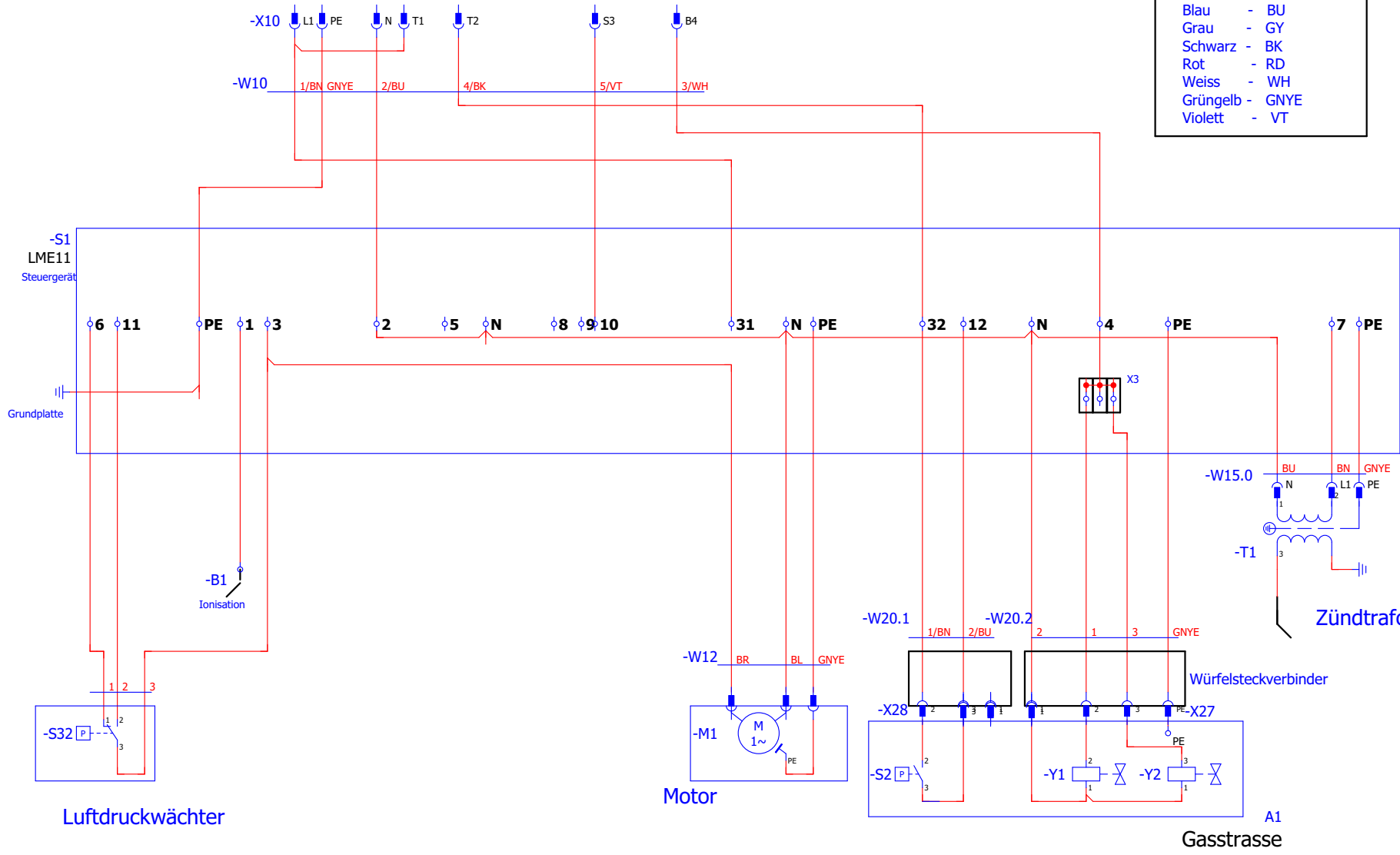

19

Wiring diagram

Service instructions/dimensions

## Declaration of conformity



Enertech GmbH, Postfach 3063, 58662 Hemer

☎ 0 23 72/965-0 ☎ 0 23 72/6 1240 ✉ info@giersch.de 🌐 www.giersch.de

### Declaration of Conformity for Gas Burners

We, Enertech GmbH, Adjutantenkamp 18 in D-58675 Hemer declare under our responsibility that

gas burner type **RG...**

is conform with the regulations of these directives

- MD2006/42/EG
- EMC2014/30/EU
- GAD 2016/426/EU
- LVD2014/35/EU
- RoHS 2011/65/EU
- DIN EN 676

and is marked with:



CE-0085

Hemer, 16.01.2018

ppa.   
Wendel  
Sales director

i.V.   
Rebbe  
Technical management

Art.-Nr. 89-10--80875 Druck-Nr. 4/2017



## Burner overall dimensions / boiler connection dimensions

All dimensions in mm

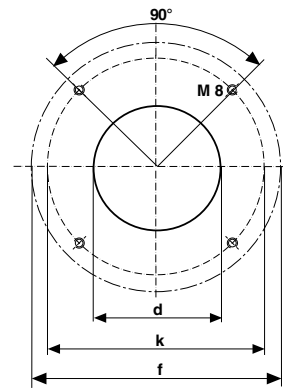
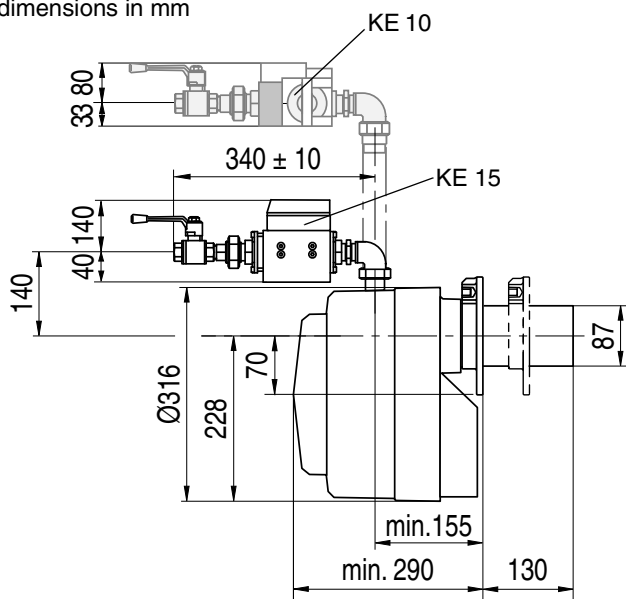

	RG1
Pipe outside dia. d	88 mm
Hole circle dia. k	150 mm
Outside dia. f	170 mm

## Working ranges

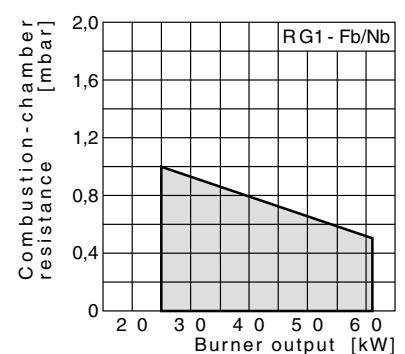
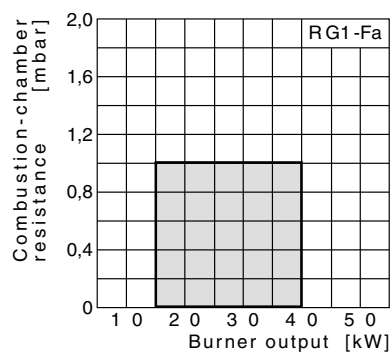
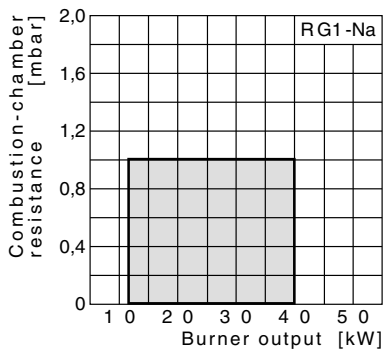

DVGW-checked working ranges as per DIN EN 676.

All information in this technical documentation as well as the drawings, photos and technical descriptions placed at your disposal remain our property and may not be duplicated without our written permission given in advance. Subject to alterations.

# GIERSCH

Giersch GmbH • Brenner und Heizsysteme  
 Adjutantenkamp 18 • D-58675 Hemer • Telephone 02372/965-0 • Fax 02372/61240  
 E-mail: info@giersch.de • Internet: <http://www.giersch.de>

