

## Technical Information • Installation Instructions

# R20 / R30

Issued April 2024  
Right reserved to effect technical  
changes in the interest of product im-  
provement !

Oil



<b>Overview .....</b>	<b>3</b>
General information .....	3
Checking scope of delivery and connection data.....	3
Operating instructions .....	3
Instruction of operating personnel.....	3
Maintenance and customer service .....	4
Key for code designation .....	4
Technical specifications .....	4
<b>Installation .....</b>	<b>5</b>
Installing flange and burner.....	5
Checking electrode setting.....	5
Establishing electrical connections .....	5
Connecting the oil .....	6
Oil pump.....	7
<b>Function .....</b>	<b>8</b>
Control unit .....	8
Flame monitor with Flame detector QRB.....	10
Air volume adjustment .....	11
Servomotor .....	12
<b>Startup .....</b>	<b>14</b>
Table of settings R20.....	14
Table of settings R30.....	15
<b>Design .....</b>	<b>16</b>
Exploded drawing and spare parts/parts list R20.....	16
Exploded drawing and spare parts/parts list R30 .....	18
<b>Service instructions/dimensions .....</b>	<b>19</b>
Boiler/burner conditioning .....	19
Smokestack connection .....	19
Exhaust gas thermometer .....	19
Service position.....	20
Control dimensions ignition electrode .....	20
Wiring diagrams .....	21
Troubleshooting .....	27
Certificate of conformity .....	28
Burner overall dimensions / boiler connection dimensions .....	32
Working ranges .....	32

# Overview

## General information

The installation of an oil-fired system must conform to extensive regulations and requirements. It is therefore the duty of the installer to be familiar with all applicable regulations and requirements. Installation, start-up and maintenance must be performed with utmost care. Fuel oil type EL to DIN 51603 must be used.

The burner must not be operated in rooms with high levels of air humidity (laundry rooms), dust or corrosive vapours.



### **Caution !**

**Improper installation, adjustment, modification, operation or maintenance may result in physical injury or damage to property/equipment.**

**Read the instructions prior to use.**

**This product must be installed in conformity with the valid regulations (e. g. DIN-VDE, DIN-DVGW).**

The design and degree of protection of the burner make it suitable for operation in enclosed rooms.

## Manually operated shut-off valve

Before the burner or typically means a manually operated shut-off valve for separating the burner must be installed. It must be easily accessible.

## Filter and venting device

Upstream of the burner, a filter must be installed to prevent the ingress of foreign matter. To vent the fuel feed line proper facilities shall be provided.

## Checking scope of delivery and connection data

Before installing the oil burner please check the items supplied for completeness.

Items supplied:

Burner, fastening unit, separate operating instructions, technical information, flange gasket, one 7-pin and one 4-pin plug-type connector (for version -Z and -ZS only).



**Oil jets are not included in the standard specifications.**

## Operating instructions

The operating instructions together with this technical information leaflet must be displayed in a clearly visible position in the boiler room. It is essential to write the address of the nearest customer service centre in the operating instructions.

## Instruction of operating personnel

Faults are often caused by operator error. The operating personnel must be properly instructed in how the burner works. In the event of recurring faults, Customer Service should be notified.

## Maintenance and customer service

The complete system should be checked once a year for correct functioning and leaks by a representative of the manufacturer or other suitably qualified person.

We accept no liability for consequential damage in cases of incorrect installation or repair, the fitting of non-genuine parts or where the equipment has been used for purposes for which it was not intended.

## Key for code designation

### R30 -Z / AE-V-L-WLE

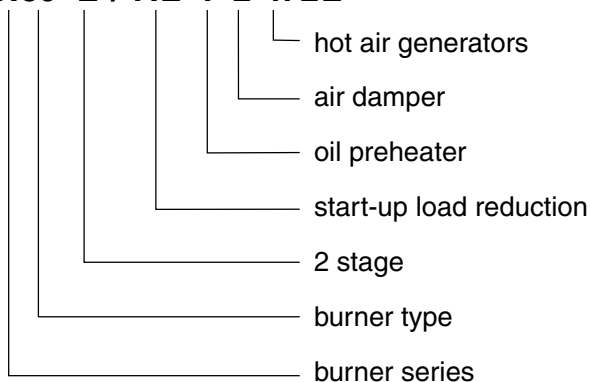

## Technical specifications

Technical data	Burner type					
	R20(-WLE)	R20-V(-WLE)	R20-AE(-WLE)	R20-ZS-L(-WLE)	R30-AE(-WLE)	R30-Z-L(-WLE)
Burner output in kW	36 - 166	36 - 77	36 - 166		95 - 273	
Boiler output in kW	33 - 153	31 - 71	33 - 153		87 - 251	
Fuel oil	Type EL, to DIN51603					
Method of operation	1-stage	1-stage	1-stage with startup relief	2-stage	1-stage with startup relief	2-stage
Voltage	1 / N / PE ~50 Hz / 230 V					
Current consumption Max. start / operation in A	2.3 / 1.1	3.2 / 2.0	2.3 / 1.1		2.8 / 1.6	
Electric motor (2850rpm) in W	180			250		
Oil pump in l/h	54			70		
Photoelectric cell	QRB4					
Control box	LMO24					
Weight in kg	16.5	17.8	17.5	18.5	29	
Noise emission in db(A)	≤ 73	≤ 65	≤ 73	≤ 73	≤ 73	
Gasburner class	3					
NOx Limit value	≤ 120 mg/kWh					

## Installation

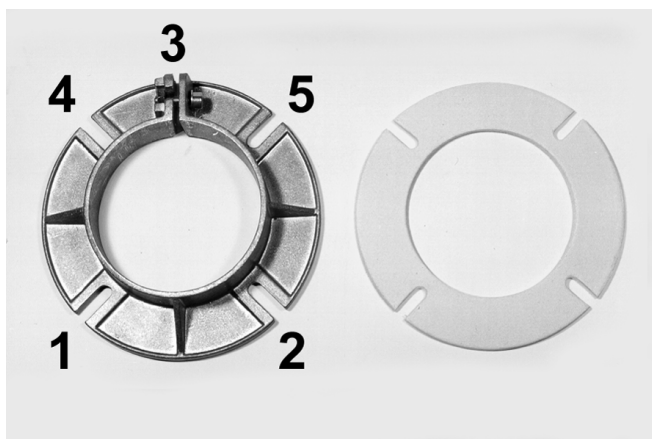

### Installing flange and burner

When installing the sliding flange, only tighten screws 1 and 2 otherwise it will not be possible to secure the burner pipe with screw 3. Slide in the burner, adjust to furnace depth and tighten the screws in the following sequence: 3, 4, 5, raising the housing in the process.

**Important:** Secure the sliding flange so that the clamping screw 3 is positioned at the top.

### Checking electrode setting

- Move the burner into the service position as described on Page 20.
- Check the ignition electrode setting (see Page 20).

## Establishing electrical connections

The electrical connection is to be made in the enclosed plug part according to the wiring plan, taking local regulations into account. The supply line must be secured with a 10 A quick-blow or 6.3 A slow-blow fuse and laid as a flexible cable. If the connector is already wired, check the connections according to the wiring diagram below.

Connection diagram for R30-Z-L

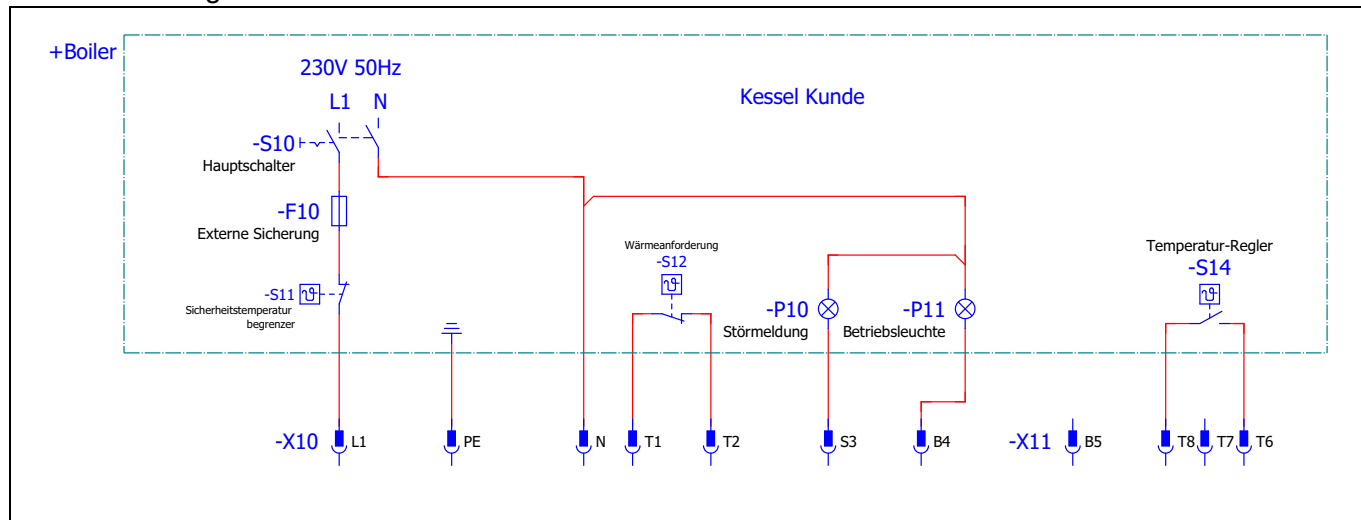

## Connecting the oil

The table refers to heating oil EL 4.8 cSt and the inner diameter of the oil pipes. In the case of the suction line length 4 elbows, 1 valve and 1 check valve have been taken into consideration for the resistance. On account of possible gassing-off of the oil, dimension X should not exceed a length of 4 mtrs.

- Using the metal hoses provided connect the oil pump to the oil line.
- The pump should be connected to the feed and return lines (two-line system).
- If the tanks are positioned higher the pump can be converted to a single-line system.

### Two-pipe system

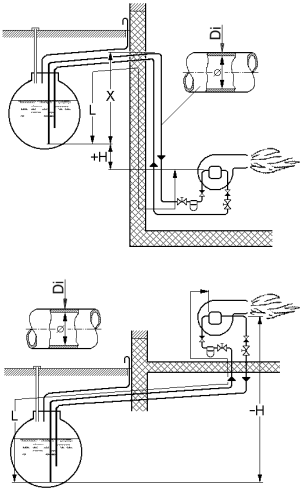

pump	Di [mm]	H [m]									
		4	3	2	1	0	-1	-2	-3	-4	
Suntec or Danfoss	6	21	18	16	13	11	8	5	-	-	
	8	67	58	50	42	34	25	17	9	-	
	10	100	100	100	100	82	62	42	21	-	

### Single pipe system

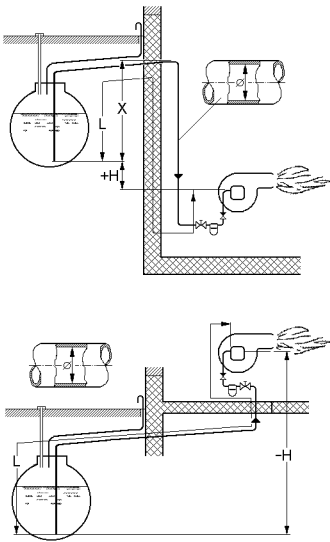

Oil throughput [kg/h]	Di [mm]	H [m]									
		4	3	2	1	0	-1	-2	-3	-4	
bis 2,5	4	77	68	58	49	40	31	22	13	-	
	6	100	100	100	100	100	100	87	64	18	
	8	100	100	100	100	100	100	100	100	56	
2,5-5,0	4	39	34	29	25	20	16	11	6	-	
	6	100	100	100	100	100	79	56	32	9	
	8	100	100	100	100	100	100	100	65	28	
5,0-10,0	4	19	17	15	12	10	8	-	-	-	
	6	98	86	74	63	51	39	28	16	4	
	8	100	100	100	100	100	100	88	51	14	
10,0-23,0	6	42	37	32	27	22	17	12	7	-	
	8	100	100	100	85	69	54	38	22	6	



For pure single-pipe operation the bypass stopper must be unscrewed out of the return line opening and the return line opening must be sealed with a gasket and metal stopper.

For conversion to single pipe system, we recommend to use a fuel oil filter with return feed. For this, the pump remains in two-pipe operation. Install flow and return burner pipes at the filter. Open the oil tap at the filter. Start the installation.

## Oil pump

On the **version -AE** (startup relief) or **-Z** (two-stage) the oil burner starts up with a low pump pressure and switches to the higher pump pressure, i.e. full output, via the solenoid valve in the pump.

**-AE** Differential pressure max. 3 bar. Ex-works setting 10 and 13 bar.

**-Z** Ex-works setting 10 and 20 bar

The pump pressure can be set for the relevant output (see Table of settings).

To do so:

- Remove the sealing plug.
- Screw in the pressure gauge and adjust the pump pressure by means of the control valve in accordance with the table of settings.

Key to Suntec pump:

- 1 = Feed line
- 2 = Return line
- 3 = Pressure pipe connection
- 4 = Pressure measuring connection
- 5 = Vacuum measuring connection
- 6 = Pressure adjustment 1st stage
- 7 = Pressure adjustment 2nd stage
- 8 = Solenoid valve 1st stage
- 9 = Solenoid valve 2nd stage

Suntec:

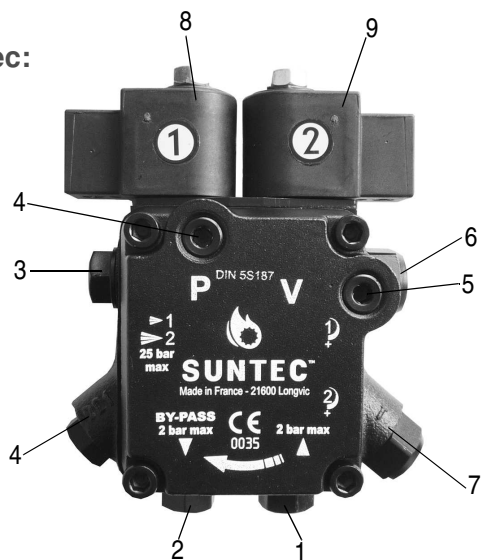

Danfoss:

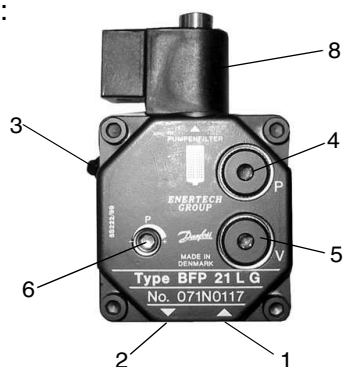

- Remove the sealing plug 4.
- Screw in the pressure gauge and adjust the pump pressure with the regulating screw 6.

Key to Danfoss pump:

- 1 = Flow
- 2 = Return
- 3 = Pressure tube connection
- 4 = Pressure measuring connection
- 5 = Vacuum measuring connection
- 6 = Pressure adjustment
- 8 = Magnetic valve

# Function

## Control unit LMO



### Testing the control unit for proper functioning

**Danger of fatal injury from electric shocks!**



**Disconnect electrical cable from power supply before carrying out any work on live parts! Troubleshooting may only be carried out by authorised and trained personnel! Unlocking may only be carried out by an authorised specialist.**

**When commissioning the plant or when doing maintenance work, make the following safety checks:**

Burner startup with flame detector darkened:

- Lockout at the end of «TSA»

Burner startup with flame detector exposed to extraneous light:

- Lockout after no more than 40 seconds.

Burner operation with simulated loss of flame:

- For that purpose, darken the flame detector during operation and maintain that state

Repetition followed by lockout at the end of «TSA»

### Safety and switching functions

If a flame failure occurs during operation, the fuel feed shuts off immediately and the system tries a restart, with pre-aeration and retarded ignition. If no flame results, the control box shows a fault after the safety time. The system restarts automatically after an interruption in the power supply. The control box shows a fault if the photo-electric cell detects a light source during the pre-aeration time, after the safety time.

### Display during commissioning

Color code table of the multi-colored signal light		
State	Color code	Color
Waiting time (tw), other waiting states	○.....	OUT
The oil preheater is heating	●.....	yellow
Ignition phase, ignition activated	○●○●○●○●○●	flashing yellow
Operation, flame OK	□.....	green
Operation, flame bad	○□○□○□○□○□	flashing green
Extraneous light when the burner starts	□▲□▲□▲□▲□▲	green-red
undervoltage	●▲●▲●▲●▲●▲	yellow-red
Fault, alarm	▲.....	red
Error code output, see error code table	○▲○▲○▲○▲○▲○	flashing red
Interface diagnosis	▲▲▲▲▲▲▲▲▲▲▲▲▲▲	red flickering light



## Legend:

- ..... Permanent  
 ○ OUT  
 ▲ red  
 ● yellow  
 □ green

**Diagnostics of the cause of fault**

After lockout, the red fault signal lamp remains steady on. In that condition, the visual diagnostics of the cause of fault according to the error code table can be activated by pressing the lockout reset button for more than 3 seconds. Pressing the reset button again for at least 3 seconds, the interface diagnostics will be activated. Interface diagnostics works only if the AGK20... lockout reset button extension is not fitted. If, by accident, interface diagnostics has been activated, in which case the slightly red light of the signal lamp flickers, it can be deactivated by pressing again the lockout reset button for at least 3 seconds. The instant of switching over is indicated by a yellow light pulse

**Error code table**

Red blink code of signal lamp (LED)	„AL“ at term. 10	Possible cause
2 x blinks	ON	No establishment of flame at the end of «TSA» - Faulty or soiled fuel valves - Faulty or soiled flame detector - Poor adjustment of burner, no fuel - Faulty ignition equipment
3 x blinks	ON	Free
4 x blinks	ON	Extraneous light on burner startup
5 x blinks	ON	Free
6 x blinks	ON	Free
7 x blinks	ON	Too many losses of flame during operation (limitation of the number of repetitions) - Faulty or soiled fuel valves - Faulty or soiled flame detector - Poor adjustment of burner
8 x blinks	ON	Time supervision oil preheater
9 x blinks	ON	Free
10 x blinks	OFF	Wiring fault or internal fault, output contacts, other faults

During the time the cause of fault is diagnosed, the control outputs are deactivated burner remains shut down.

The diagnostics of the cause of fault is quit and the burner switched on again by resetting the burner control. Press the lockout reset button for about 1 second (<3 seconds).

## Flame monitor with Flame detector QRB



The flame detector is used for monitoring of burning oil flames and for ignition spark.

Trouble-free burner operation is ensured only when the intensity of UV radiation at the detector's location is high enough for the detector's UV cell to ignite during each half wave.

### **Operability check:**

A safety check of the flame failure system must be carried out when the appliance is first commissioned and after any inspections or long periods of inactivity.

### **Start-up test with flame detector covered:**

After expiry of the safety period, the burner should perform a safety cut-out.

### **Start-up test with flame detector illuminated:**

After approx. 20 s of pre-aeration the burner must go over to fault.

### **Standard. Startup; if burner in operation, darken the flame detector:**

Attempt startup again, at the end of the safety time the burner must go over to fault.

**R20**

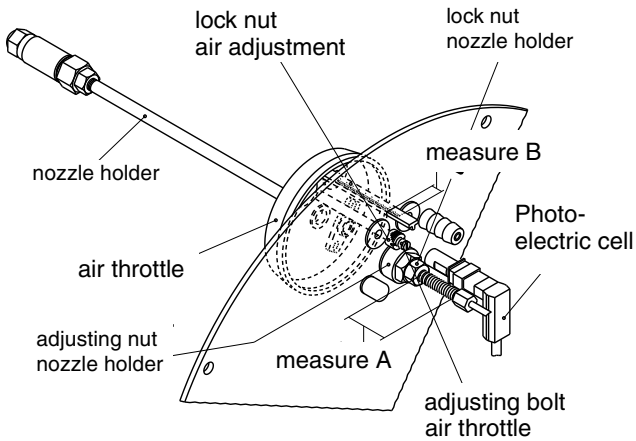

**Air volume adjustment**

Dimensions "A" and "B" serve as orientation aids for easier adjustment of the air volume, which is altered in conformity with the nozzle selection tables, depending on the output. Adjustment is effected via the adjusting nut (dimension "A") or via the adjusting screw (dimension "B"). If there is overpressure in the furnace, set dimension "A" lower and dimension "B" higher. If there is underpressure in the furnace, set dimension "A" higher and dimension "B" lower than the dimensional specifications in the nozzle selection table. The flame pattern can be influenced more favorably with the aid of the air throttle adjuster. The tables are for the purpose of presetting. Readjustment is required in any case in relation to the installation. After adjustment of the optimal combustion values the two lock nuts have to be tightened.

**R30**

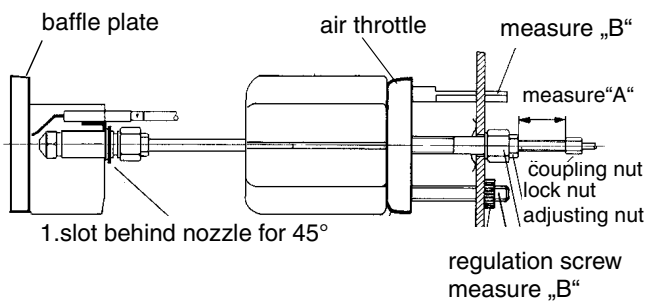

**R20 without preheating**

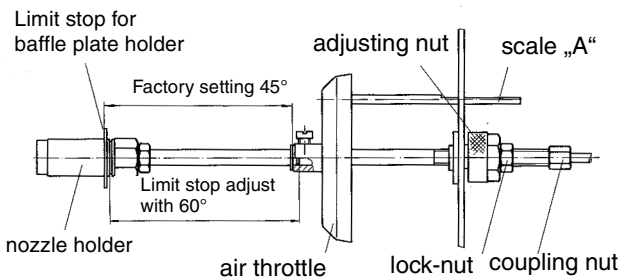

**R20-V-L**

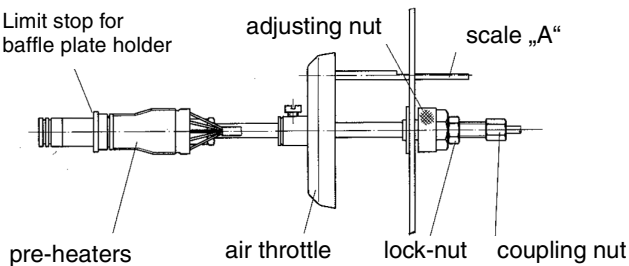



## Servomotor

(version -Z-L, -ZS-L, 2-stage with automatic economy device)

The air valve positioning motor adjusts the air valve position or trips the solenoid valve on two-stage burners with air shutoff. Adjustment is via limit switch cams on the positioning drive roller.

You can refer to the presetting table for the cam positions for adaptation of the burner to the requisite boiler output.

For this:

Remove cover from air valve positioning motor. Alter the cam positions via the adjusting screws with a standard screwdriver.

The switching cams can be readjusted when the burner is adjusted.

**Higher setting = More air, pressure increases**

**Lower setting = Less air, pressure decreases**

Please note the following when adjusting the switch cams:

- Do not set cam position ST1 higher than ST2.
- Set cam position MV2 roughly 10°-20° above cam position ST1.
- Check cam position MV2 after correcting cam position ST1.
- After adjusting ST1 and ST2 it is necessary to switch over to the next stage so that the adjustment becomes effective.
- After having readjusted the burner, refasten the servomotor hood and set the switch on the lower part of the control unit to the position 2nd stage.

## Version -L (single-stage with automatic economy device)

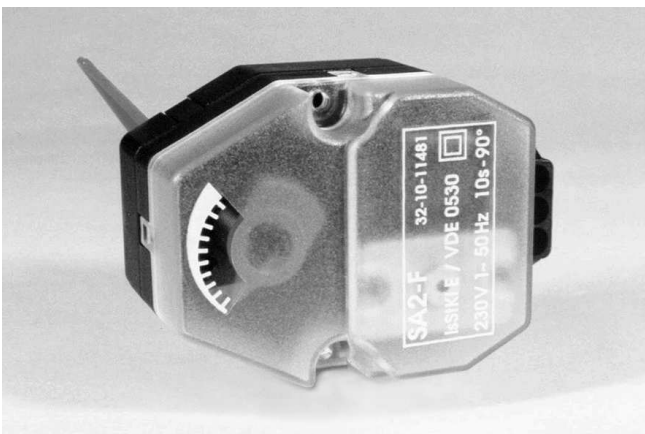

On version -L burners an air damper prevents the furnace from cooling down when there is a burner stoppage. Control of the air damper is effected electrically. The air flap opens before the burner starts. Its position can be read off the servomotor.

Position indicator "OPEN"- "CLOSED". For servicing/retrofitting heed wiring diagram.



Do not turn red positioning lever by hand as mechanism is destructible.

---

### **Version V (with oil preheating)**

The oil preheating is upline from the burner program sequence and remains in operation until the oil burner is switched off by the control thermostat. The switch-on status of the preheater is indicated by a control lamp in the bottom part of the control device. The cold-start disable is effected via a thermostat, which is integrated into the preheater, and which does not enable the supply of current to the control device until the heating-up has taken place. The electrical preheater is integrated into the nozzle holder and has a controlled heating output. This is adapted via a resistor to the relevant heat requirement.

# Startup

## Adjustment tables

### R20(-AE)

Burner output	Boiler output where $\eta_k = 92\%$	Nozzle size	Nozzle spray angle	Oil pump pressure*	Oil throughput	Nozzle stem position dimension "A"
[kW]	[kW]	[USgal/h]	[°]	[bar]	[kg/h]	[mm]
40	37	0.75	60°S	13	3.4	13
45	41	0.85	60°S	13	3.8	15
55	51	1.00	60°S	13	4.6	16
60	55	1.10	60°S	13	5.1	18
65	60	1.25	45°S	13	5.5	19
75	69	1.35	45°S	13	6.3	20
85	78	1.50	45°S	13	7.2	22
95	87	1.75	45°S	13	8.0	23
110	101	2.00	45°S	13	9.3	26
125	115	2.25	45°S	13	10.6	29
140	129	2.50	45°S	13	11.8	32
150	138	2.75	45°S	13	12.7	39
165	152	3.00	45°S	13	13.9	50

\*Startup relief pressure 10 bar

### R20-V

Burner output	Boiler output where $\eta_k = 92\%$	Nozzle size	Nozzle spray angle	Oil pump pressure	Oil throughput	Nozzle stem position dimension "A"
[kW]	[kW]	[USgal/h]	[°]	[bar]	[kg/h]	[mm]
35	32	0.85	60°S/45°S	9.5	3.0	14
39	36	1.00	60°S/45°S	8.5	3.4	16
46	42	1.25	45°S	8.5	4.0	17
52	48	1.50	45°S	8.5	4.5	19
59	54	1.75	45°S	8.5	5.1	20
65	60	2.00	45°S	8.5	5.6	21
72	66	2.25	45°S	8.5	6.2	22

## R20-ZS-L

Burner output		Boiler output where $\eta_k=92\%$	Nozzle size	Nozzle spray angle	Oil pump pressure		Oil throughput		Nozzle stem position dimension "A"	Air throttle position dimension "B"	Servomotor				Compression	
ST2	ST1				ST2	ST1	ST2	ST1			ST0	ST2	MV2	ST1	ST1	ST2
[kW]	[kW]	[kW]	[USgal/h]	[°]	[bar]	[bar]	[kg/h]	[kg/h]	[mm]	[mm]					[mbar]	[mbar]
49	36	45	0.75	60°S	20	10	4.2	3.0	7 - 9	15-17	0	80	10	5	3	6
56	39	52	0.85	60°S	20	10	4.8	3.3	9 - 11	16-19	0	80	15	8	3	6
66	43	61	1.00	45°S	20	10	5.	3.7	12-14	18-20	0	80	15	9	3	6
72	51	68	1.10	45°S	20	10	6.1	4.3	14 - 16	21-23	0	80	25	18	3	6
81	57.5	75	1.25	45°S	20	10	6.9	4.8	16-18	22-24	0	105	30	15	3	6
89	64	82	1.35	45°S	20	10	7.5	5.4	17-19	29-31	0	105	50	20	3	6
97	61	89	1.50	45°S	20	10	8.2	5.2	19-21	36-38	0	105	50	25	3	6
111	77	102	1.75	45°S	20	10	9.4	6.5	21-23	42-44	0	105	50	30	3	6
129	90	119	2.00	45°S	20	10	10.9	7.6	27-29	47-50	0	105	50	32	3	6
142	101	131	2.25	45°S	20	10	12.0	8.5	29-31	47-50	0	105	50	35	2.5	5
153	114	141	2.50	45°S	20	10	12.9	9.7	48-52	47-50	0	105	60	40	2.5	5

## R30-AE

Burner output	Boiler output where $\eta_k = 92\%$	Nozzle size	Nozzle spray angle	Oil pump pressure*	Oil throughput	Nozzle stem position dimension "A"	Nozzle stem position dimension "B"
[kW]	[kW]	[gph]	[°]	[bar]	[kg/h]	[mm]	[mm]
100	92	1.75	45°S	15	8.5	43	21
115	106	2.00	45°S	15	9.7	38	24
130	120	2.25	45°S	15	11.0	35	30
150	138	2.50	45°S	15	12.7	33	33
160	147	2.75	45°S	15	13.5	32	36
180	166	3.00	45°S	15	15.2	30	38
220	202	3.75	45°S	15	18.6	26	50
255	235	4.50	45°S	15	21.5	18	85
280	258	5.00	45°S	15	23.6	11	85

\*Startup relief pressure 12 bar

## R30-Z-L

Burner output		Boiler output where $\eta_k=92\%$	Nozzle size	Nozzle spray angle	Oil pump pressure		Oil throughput		Nozzle stem position dimension "A"	Air throttle position dimension "B"	Servomotor			
ST2	ST1				ST2	ST1	ST2	ST1			ST0	ST2	MV2	ST1
[kW]	[kW]	[kW]	[gph]	[°]	[bar]	[bar]	[kg/h]	[kg/h]	[mm]	[mm]				
143	102	132	2.25	45°S	20	10	12.0	8.6	32-36	38-40	0	115	55	45
160	113	147	2.50	45°S	20	10	13.4	9.5	30-33	42-44	0	115	60	50
176	124	162	2.75	45°S	20	10	14.8	10.4	28-31	44-46	0	115	60	50
195	138	179	3.00	45°S	20	10	16.4	11.6	25-28	43-47	0	115	65	55
217	156	200	3.50	45°S	20	10	18.2	13.1	22-25	52-56	0	115	65	55
247	179	227	4.00	45°S	20	10	20.8	15.0	14-18	59-63	0	115	75	60
273	203	254	4.50	45°S	20	10	23.0	17.1	5-7	88-92	0	115	80	65

## Design

R20(-V)

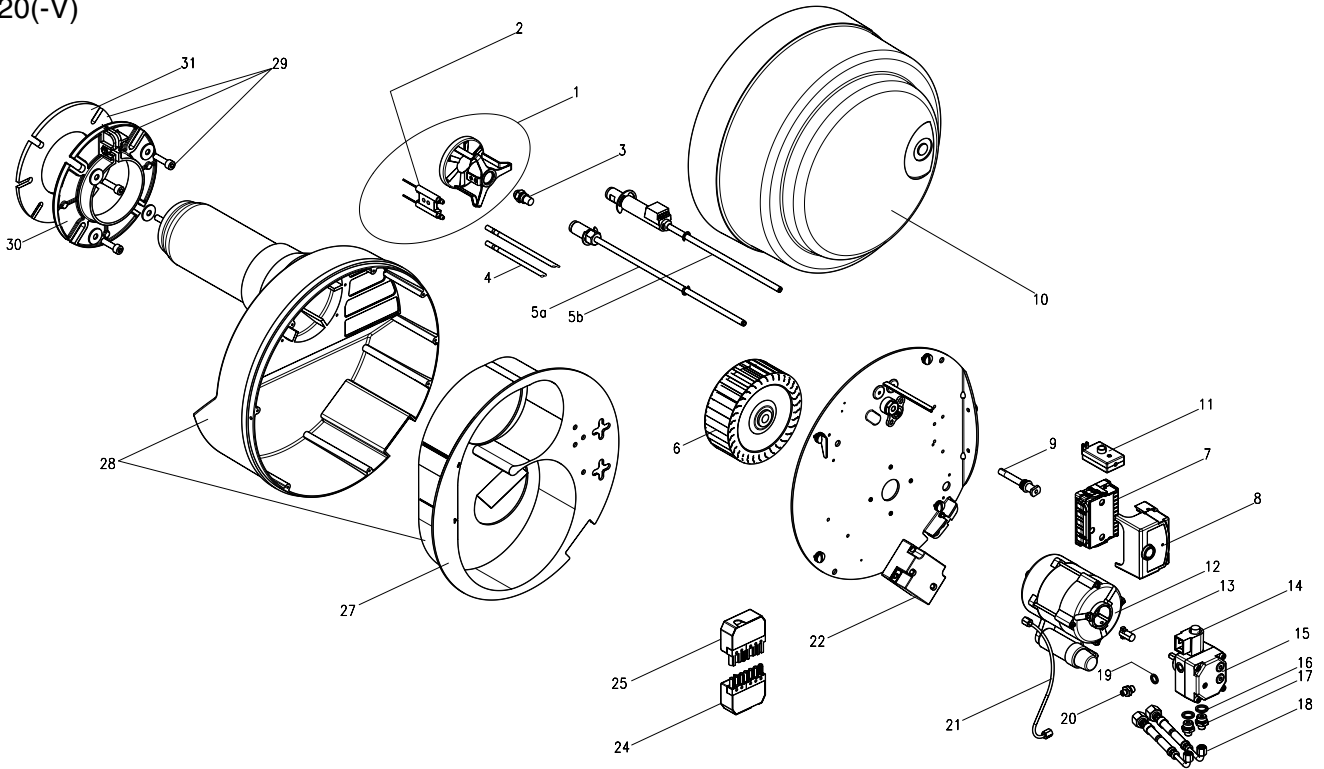

ZBZ\_1-766

Seq. No.	Designation	PU	Order No.
1	Diaphragm plate with retainer and twin electrode for WLE		47-90-21254
1	Diaphragm plate with retainer and twin electrode		32-90-10143
2	Twin electrode for WLE	5	33-50-10711
2	Twin electrode R20	5	32-90-20642
3	Nozzle		on request
4	Ignition cable 640 mm long	2	47-50-26741
5a	Nozzle stem for R20		32-90-11509
5b	Nozzle stem with oil preheater and cable for R20-V		52-90-21342
6	Fan dia. 146 x 62 mm		32-90-10139
7	Lower section, control box		37-90-11310
8	Control unit LMO24		47-90-28928
8	Control unit LMO14		47-90-26320
9	Flame detector QRB		47-90-29981
10	Burner cover		32-90-11742
11	Safety switch		32-90-11499
12	Motor 230 V / 50 Hz 180 W with cable		32-90-11507
13	Coupling for motor	10	37-50-11586
14	Solenoid valve for BFP		47-90-29443
15	Oil pump BFP 21 LG with connection parts		47-90-10834
-	Filter insert for BFP pump		59-90-50470
16	Gasket 13 x 18 x 2	50	37-50-11293
17	Hose stem R1/4 x 6 LL	10	47-50-20862
18	Oil hose NW4 1200 mm long	2	47-90-10802
19	Gasket 10 x 14 x 2	50	37-50-10788
20	Pressure pipe stem dia. 1/8	5	37-50-20200
21	Pressure pipe for oil pump - nozzle stem		31-90-23246
22	Ignition transformer mod. 26/35		47-90-24469
24	Plug unit, 7-pin, black/brown		37-50-11015
25	Socket unit 7-pin black/brown with cable		37-90-20731
27	Plastic housing insert		32-90-11744
28	Housing with burner pipe		32-90-11508
29	Montage set (pos. 29, 30 , 31)		47-90-27335
31	Flange gasket	5	32-50-10261
-	Attachment screw for burner cover		47-90-28030
-	Motor cable		47-90-11804
-	Replacement set of quick release fasteners R R1 / R20 / RG1 / RG20		47-90-29351



## R20-ZS-L(-AE)-

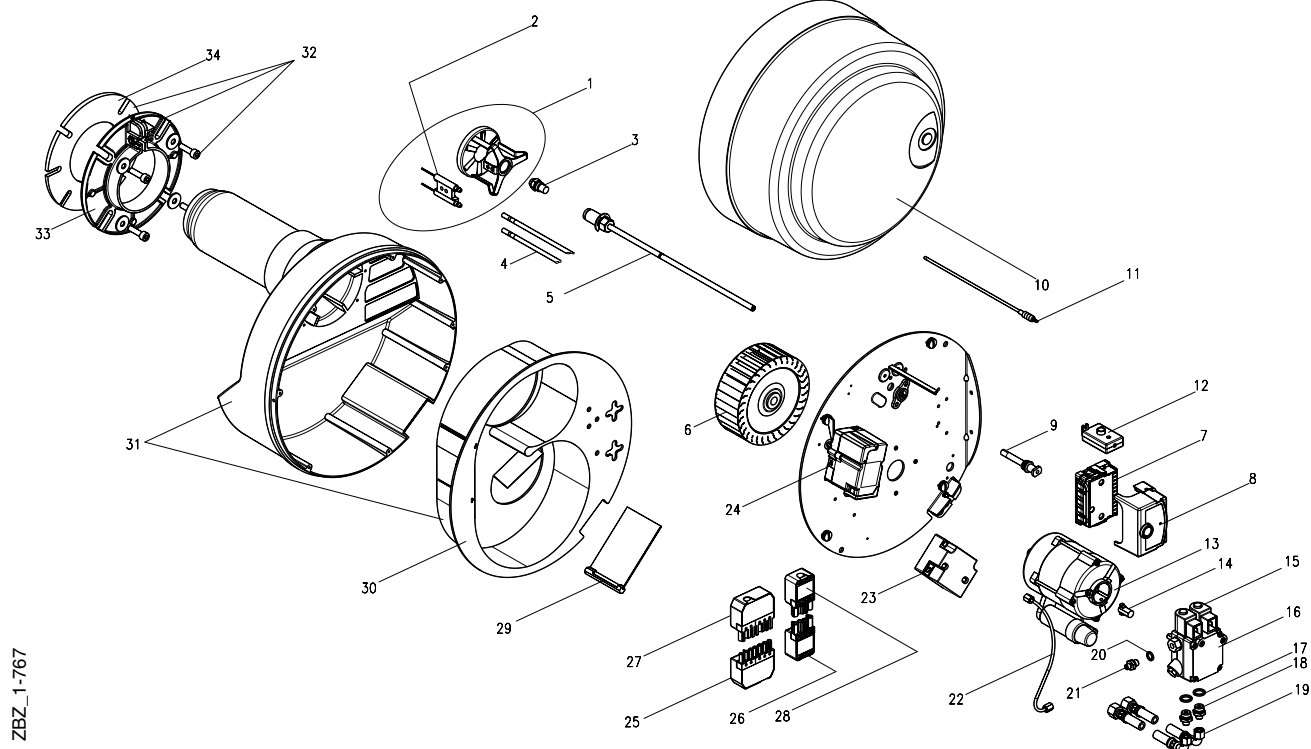

ZBZ\_1-767

Seq. No.	Designation	PU	Order No.
1	Diaphragm plate with twin electrode (for fan-assisted air heater)		47-90-21254
1	Diaphragm plate with retainer and twin electrode		32-90-10143
2	Twin electrode for WLE	5	33-50-10711
2	Twin electrode R20	5	32-90-20642
3	Nozzle		on request
4	Ignition cable 640 mm long	2	47-50-26741
5	Nozzle stem		32-90-12650
6	Fan dia.146 x 62 mm		32-90-10139
7	Lower section, control box		37-90-11310
8	Control unit LMO24		47-90-28928
9	Flame detector QRB		47-90-29981
10	Burner cover		32-90-11742
11	Measuring stem dia. 4 x 1 150 mm long		42-90-23254
12	Safety switch		32-90-11499
13	Motor 230 V / 50 Hz 180 W with cable		32-90-11507
14	Coupling for motor	10	37-50-11586
15	Solenoid valve for Oil pump AS, AT and ALE		47-90-12582
16	Oil pump AT 245 with connection parts		47-90-12645
17	Gasket 13 x 18 x 2	50	37-50-11293
18	Hose stem ND 6 dia. 1/4"	10	37-50-11348
19	Oil hose ND 6 1200 mm long	2	47-90-11347
20	Gasket 10 x 14 x 2	50	37-50-10788
21	Pressure pipe stem dia. 1/8"	5	37-50-20200
22	Pressure pipe for oil pump -nozzle stem		31-90-23246
23	Ignition transformer mod. 26/35		47-90-24469
25	Plug unit, 7-pin, black/brown		37-50-11015
26	Plug unit 4-pin, black/green		37-50-11143
27	Socket unit 7-pin black/brown with cable		37-90-20731
28	Socket unit, 4-pin, green, with cable		47-90-11840
29	Air flap		32-90-10176
30	Plastic housing insert		32-90-11744
31	Housing with burner pipe		32-90-11508
31	Housing with burner pipe, 100 mm long		47-90-26343
32	Montage set (pos. 32,33,34)		47-90-27335
34	Flange gasket		32-50-10261
-	Attachment screw for burner cover		47-90-28030
-	Motor cable		47-90-11804
-	Replacement set of quick release fasteners R R1 / R20 / RG1 / RG20		47-90-29351

## R30-AE / R 30-Z-L

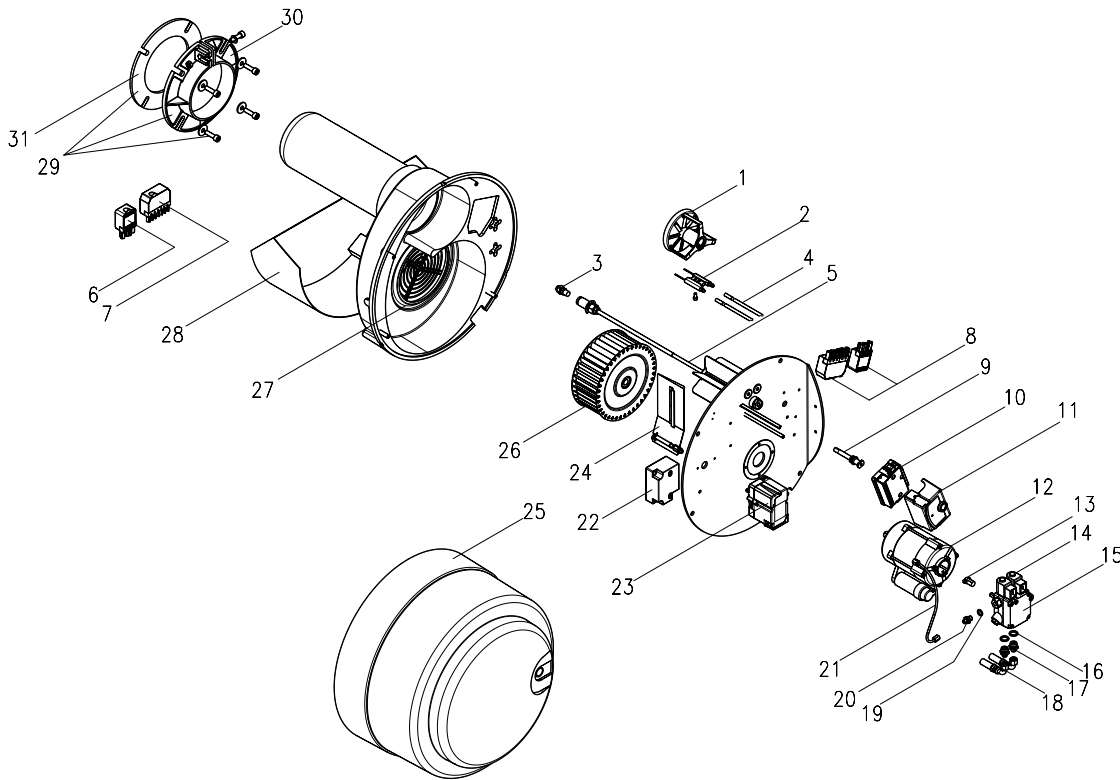

ZBZ\_1-765

Seq. No.	Designation	PU	Order No.
1	Retarding disc with retainer and twin electrode		33-90-10708
2	Twin electrode	5	33-50-10711
3	Nozzle		on request
4	Ignition cable 640 mm long	2	47-50-26741
5	Nozzle stem		33-90-10706
6	Plug unit 4-pin, black/green		37-50-11143
7	Plug unit, 7-pin, black/brown		37-50-11015
9	Socket unit, 11-pin,		37-90-11135
9	Flame detector QRB		47-90-29981
10	Lower section, control unit		39-90-11310
11	Control unit LMO24		47-90-28928
12	Motor 230 V / 50 Hz 350 W		33-90-10335
13	Coupling for motor	10	37-50-11586
14	Solenoid valve for Oil pump AS, AT and ALE		47-90-12582
15	Oil pump AT245 with connection parts		47-90-12645
-	Pump filter kit for AS/AT pump with seal		47-90-23325
16	Gasket AL 13 x 18 x 2	50	37-50-11293
17	Hose stem ND 6 dia. 1/4	10	37-50-11348
18	Oil hose ND 6 1200 mm long	2	47-90-11347
19	Gasket 10 x 14 x 2	50	37-50-10788
20	Pressure pipe stem dia. 1/8	5	37-50-20200
21	Pressure pipe for oil pump nozzle stem		31-90-23246
22	Ignition transformer mod. 26/35		47-90-24469
23	Actuating drive STA 3.5 B0		47-90-24393
24	Spare parts set Air flap R/RG		43-50-23298
25	Burner cover		33-90-30204
26	Impeller dia. 180 x 75 mm		33-90-10590
27	Housing with burner pipe		33-90-11926
27	Housing R30		47-90-24601
28	Intake silencer		33-90-12009
29	Montage set (pos. 29,30,31)		33-90-11011
31	Flange gasket	5	33-50-10191
-	Motor cable		47-90-11804
-	Motor relay for motors > 180 W with additional capacitor		47-90-28065

## Service instructions/dimensions

### Boiler/burner conditioning

Precise boiler/burner conditioning is necessary for low-emission and energy-saving combustion. For this purpose a burner is assigned to the boiler in accordance with the working ranges (Page 32) and in consideration of the resistance at the heating gas face. The insertion depth of the burner tube is optimally adjusted by way of the sliding flange to the relevant combustion chamber.

### Smokestack connection

The prerequisite for perfect operation of the furnace is a correctly dimensioned smokestack.

Dimensioning is effected in accordance with DIN 4705 in consideration of DIN 18160 and based on the boiler and burner outputs.

For operation on a sliding basis, provide smokestacks as per DIN 18160 part, group 1. The exhaust gas mass flow of the total rated heat output must be put in for the calculation. The effective smokestack height is counted from burner level. Furthermore, we refer you to the statutory building regulations of the individual German federal states.

Select a smokestack design so that the danger of condensation or of a cold smokestack inner wall is reduced to a minimum.



**For exact adjustment and stabilization of the smokestack draught we recommend the installation of a draught limiter.**

By this means:

- any draught fluctuations are equalized
- moisture in the smokestack is largely excluded
- stoppage losses are reduced.

Connection pieces should be introduced into the smokestack with a gradient of 30° or 45° viewed in flow direction. It is best to provide exhaust gas pipes with thermal insulation.

**Important:**For the refurbishment of existing installations, over-dimensioned smokestack cross-sections or unsuitable smokestacks are very often specified for NT operation etc. We recommend that you make an appraisal of the smokestack system together with the responsible local chimney sweep prior to installing the boiler plant so that suitable refurbishing measures can also be defined at an early stage for the smokestack (e.g. insertion of a stainless steel pipe, centrifuging of the flue, installation of an induced draught ventilator).

### Exhaust gas thermometer

For exhaust gas temperature monitoring the heating system should be equipped with an exhaust gas thermometer. The higher the exhaust gas temperature, the greater the exhaust gas loss.

Rising exhaust gas temperatures indicate increasing deposits that will reduce the degree of combustion efficiency.

In the event of an increasing exhaust gas temperature have the heating installation cleaned and readjusted by a skilled person.

R 20 / R 30

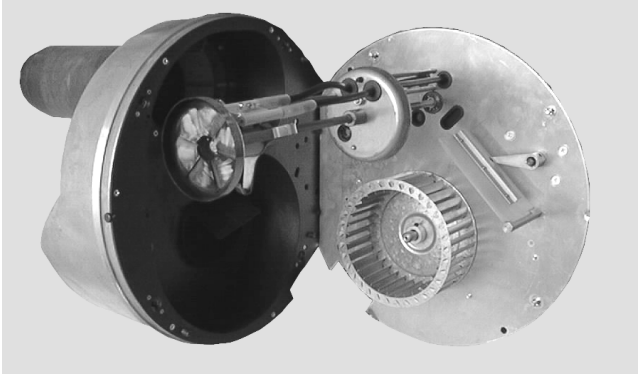

### Servicing position



**Risk of injury by fan wheel during activation in service position.**

- Release quick-release locks and detach base plate.
- Suspend base plate with retaining buttons in cross recesses of housing.

R 20

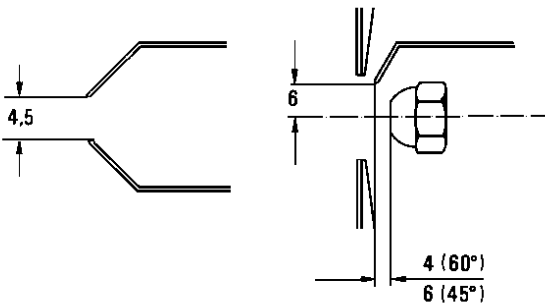

### Control dimensions for the ignition electrode

The ignition electrodes are preset. The specified dimensions (Fig.) are for control purposes.

R 20-WLE / R 30(-WLE)

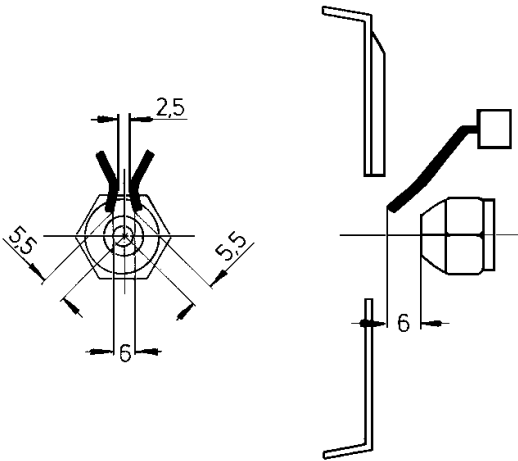

SP\_1-1037.2

Aderfarben	
Braun	- BN
Blau	- BU
Grau	- GY
Schwarz	- BK
Rot	- RD
Weiss	- WH
Grünelb	- GNYE
Violett	- VT

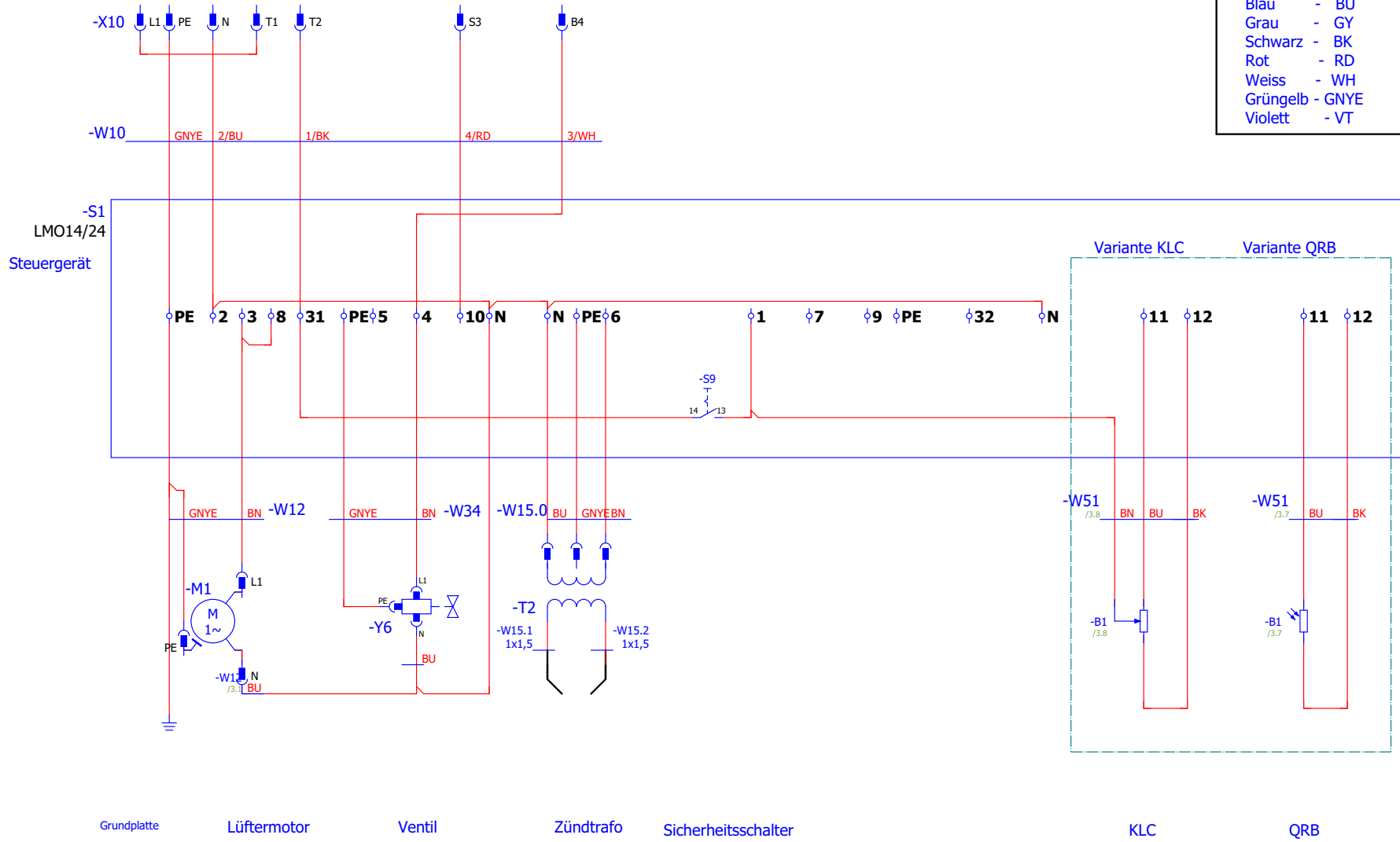

21

Wiring diagrams  
R20

Service instructions/dimensions

Aderfarben	
Braun	- BN
Blau	- BU
Grau	- GY
Schwarz	- BK
Rot	- RD
Weiss	- WH
Grünelb	- GNYE
Violett	- VT

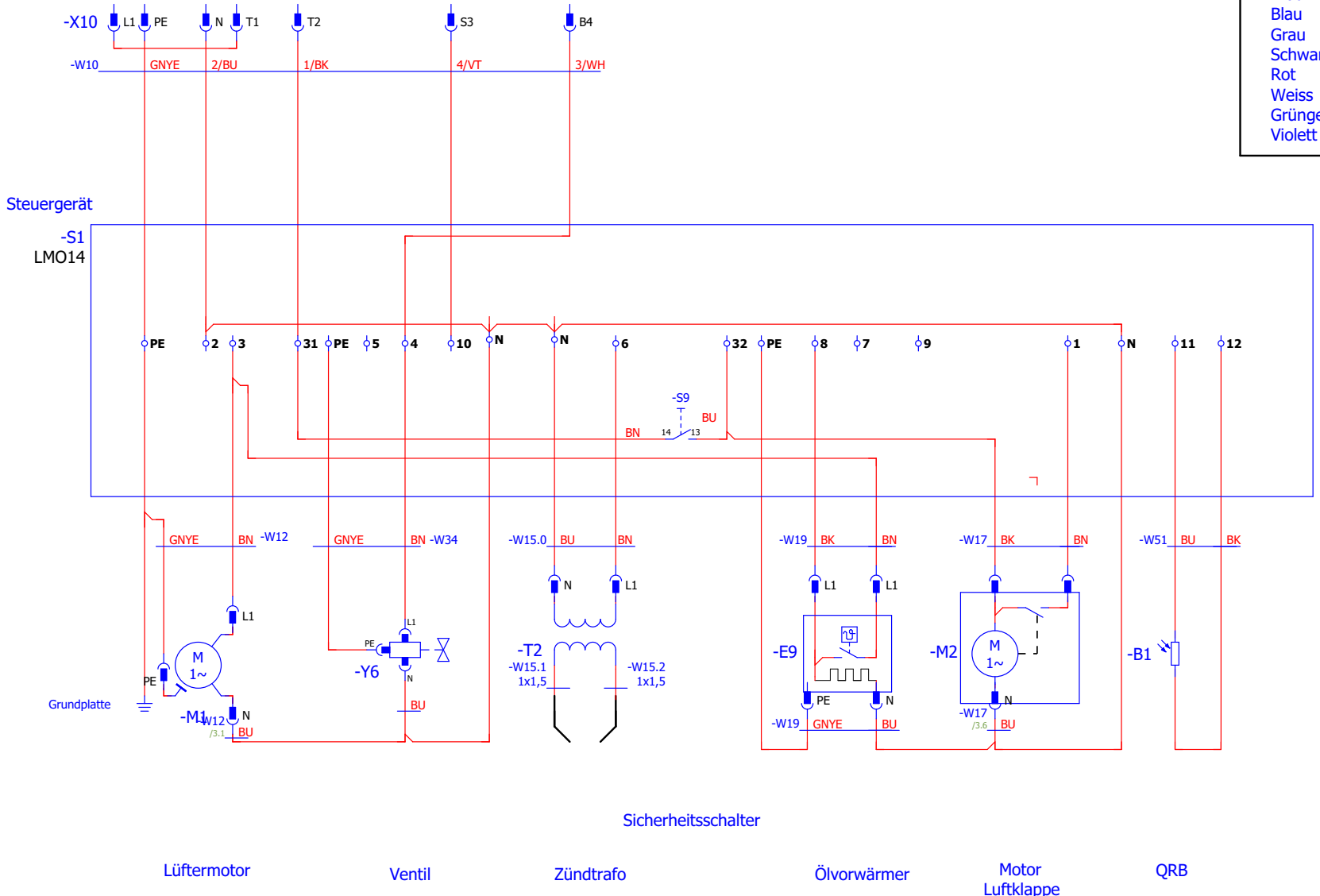

SP\_1-1049.2

R20-AE

Aderfarben	
Braun	- BN
Blau	- BU
Grau	- GY
Schwarz	- BK
Rot	- RD
Weiss	- WH

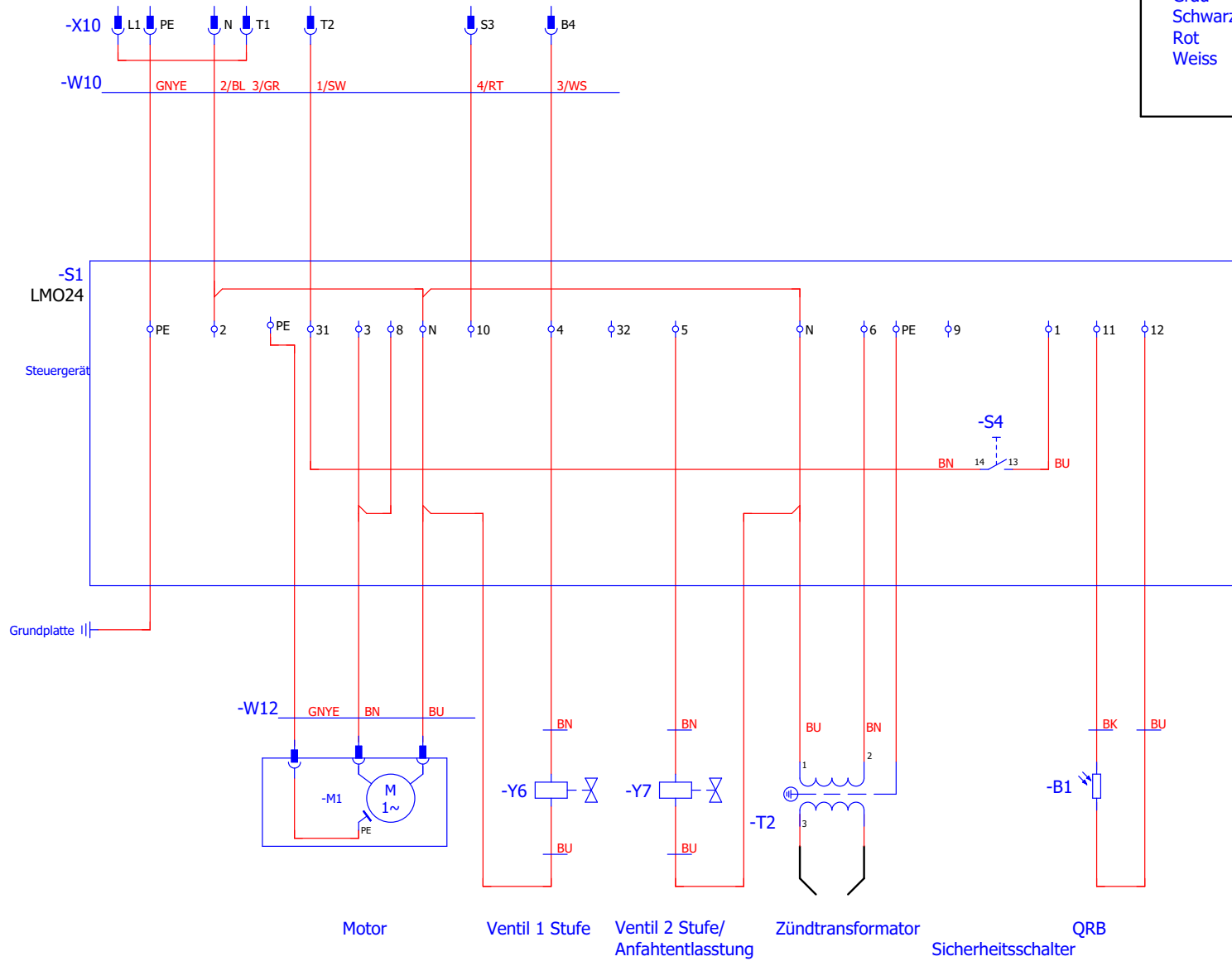

23

Service instructions/dimensions

Aderfarben	
Braun	- BN
Blau	- BU
Grau	- GY
Schwarz	- BK
Rot	- RD
Weiss	- WH
Grüngelb	- GNYE
Violett	- VT

24

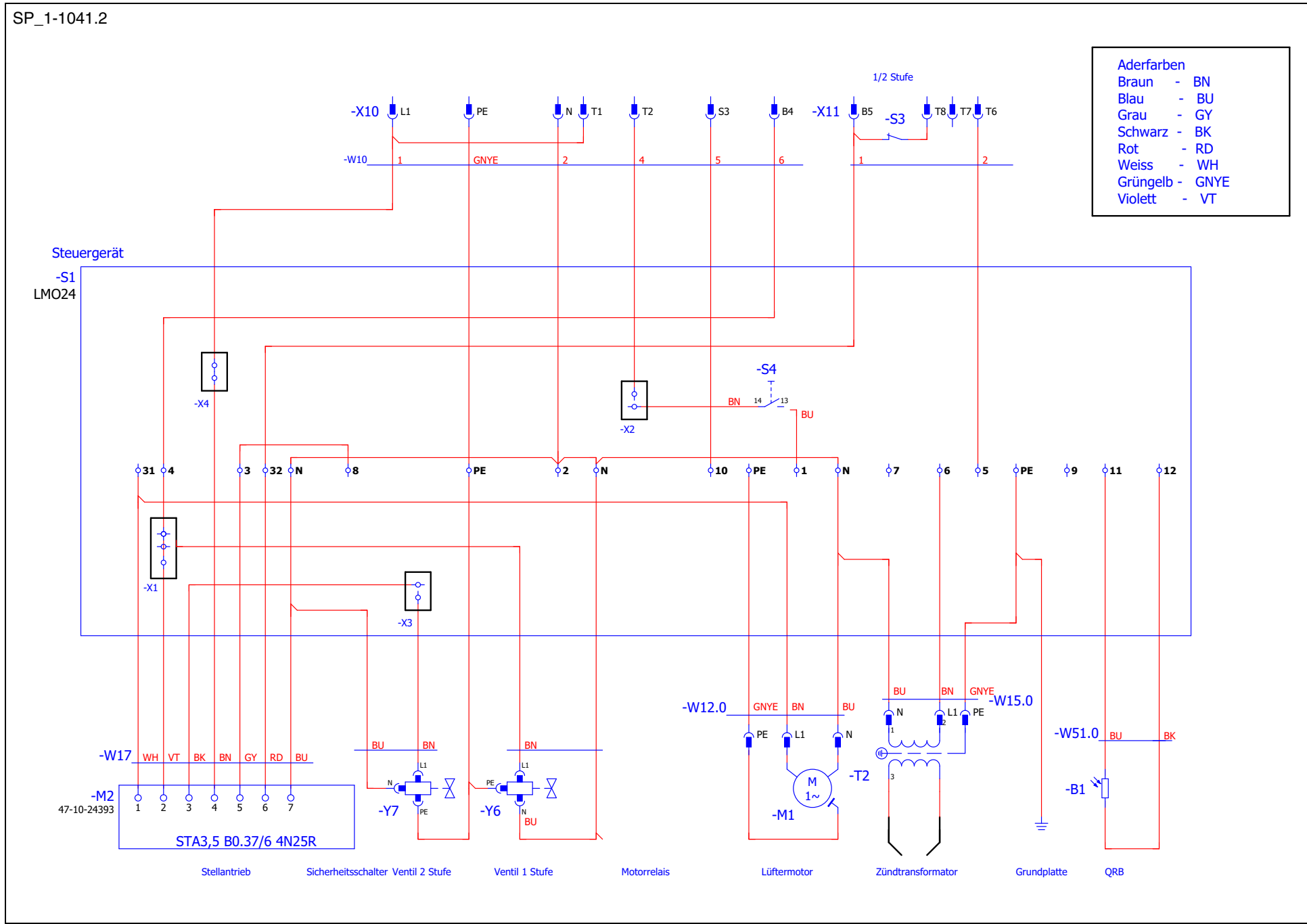



SP\_1-1038.1

Aderfarben	
Braun	- BN
Blau	- BU
Grau	- GY
Schwarz	- BK
Rot	- RD
Weiss	- WH
Grünelb	- GNYE
Violett	- VT

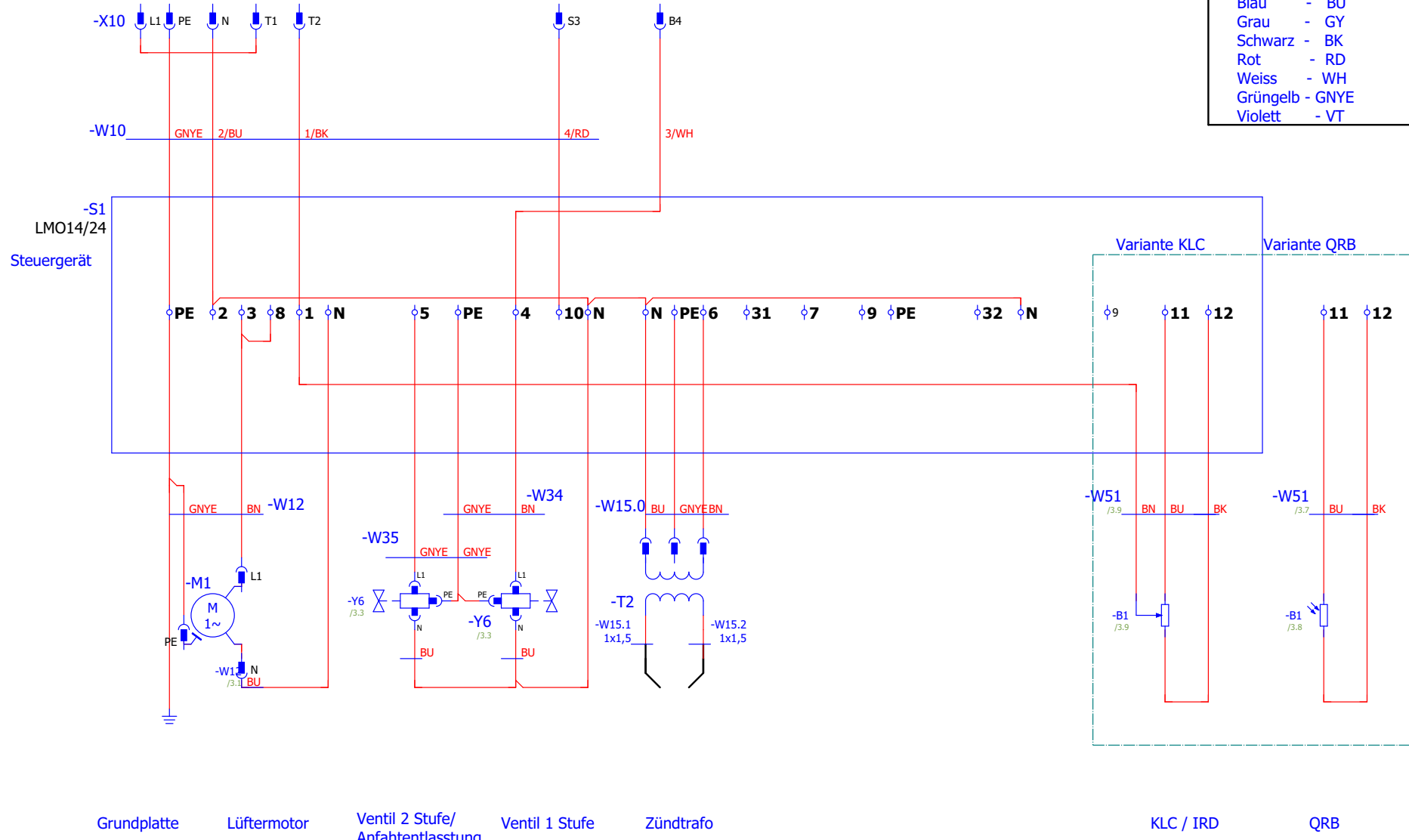

Grundplatte

Lüftermotor

Ventil 2 Stufe/  
Anfahrterlastung

Ventil 1 Stufe

Zündtrafo

KLC / IRD

QRB

Aderfarben	
Braun	- BN
Blau	- BU
Grau	- GY
Schwarz	- BK
Rot	- RD
Weiss	- WH
Grüngelb	- GNYE
Violett	- VT

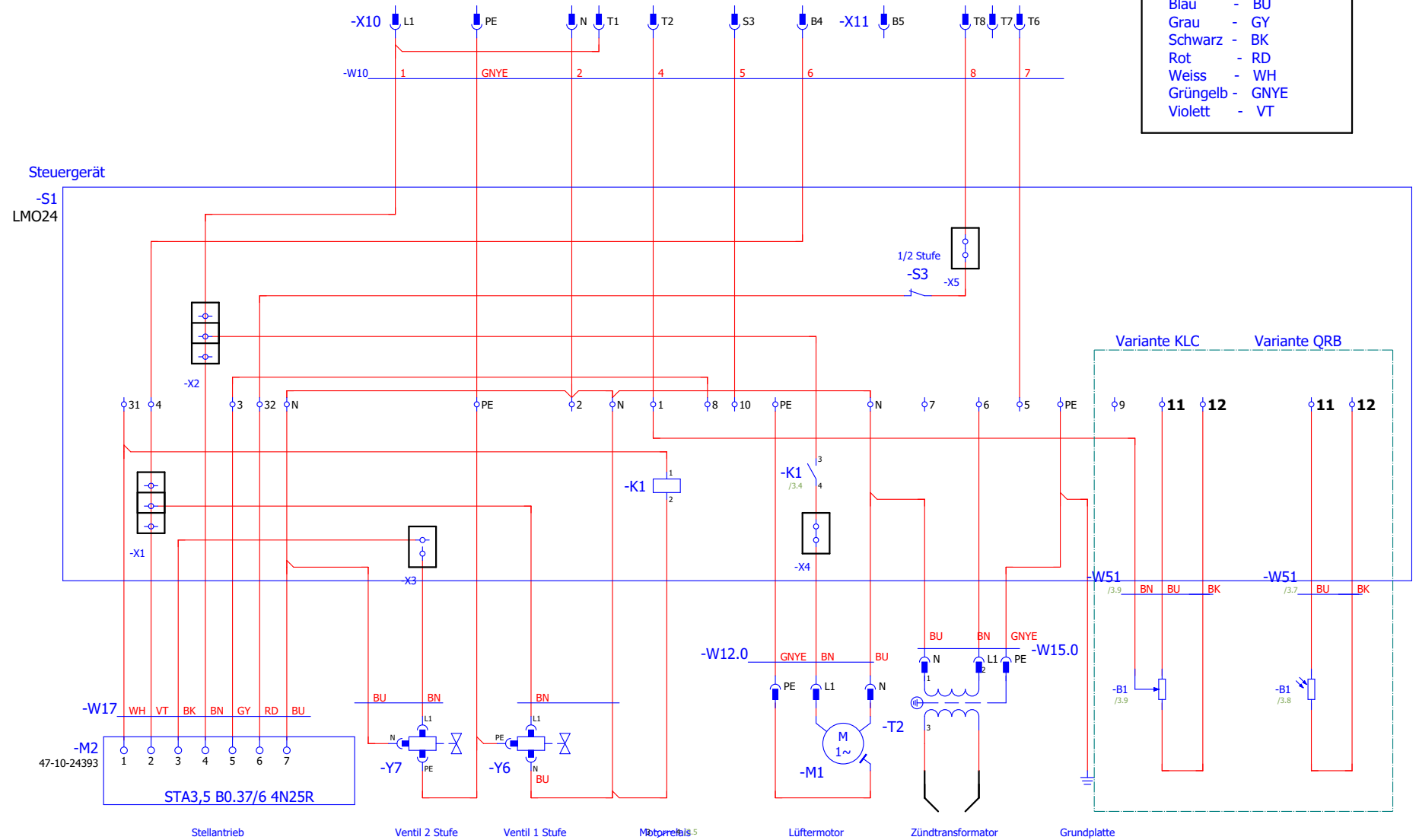

## Troubleshooting

Fault	Cause	Elimination
Burner motor will not run	Fuse defective Safety thermostat locked Temperature of the controller adjustment exceeded Control box defective Motor defective Oil preheater: heater or thermostat enable defective Air valve positioning motor does not open or does not switch through Coupling motor/pump defective Mains voltage too low	Replace Unlock After temperature drop make new attempt to start Replace Replace Replace Replace Provide adequate mains voltage
Burner starts up (does not start up) and after expiry of the safety period switches to fault	a) With flame: Flame failure controller soiled, defective, not properly plugged in or not correctly adjusted Control device defective b) Without flame formation: No ignition  Burner receiving no oil: Valves, oil line closed Oil tank empty Filter soiled Oil line leaky Pump defective Foot-actuated valve leaky Nozzle soiled or defective Solenoid valve defective Filter in solenoid valve blocked External light source Coupling motor/pump defective Oil preheater blocked Mains voltage more than 15 % under rated value	Clean, replace, plug in correctly Replace Check ignition electrode and adjustment, ignition transformer and cable  Open Top up oil Clean Seal Replace Seal Replace nozzle Replace Clean filter and replace solenoid valve see Functional control of control device Replace Replace Provide adequate mains voltage
Flame extinguishes during operation	Oil supply consumed Nozzle filter blocked Oil filter or oil feed lines soiled Air inclusions Solenoid valve defective	Top up oil Clean nozzle filter or replace nozzle Clean filter and lines Check suction line and fittings Replace
Mixing unit very oily or has intense coke scaling	Wrong adjustment Wrong nozzle size Incorrect quantity of combustion air Furnace room not enough ventilated	Correct the adjustment measures Replace Readjust the burner Ensure sufficiently large aeration apertures
Burner operating intermittently	Oil throughput excessive	Install a control device with interception circuit

## Certificate of conformity



Wärme für die Zukunft.

Giersch GmbH | Adjutantenkamp 18 | 58675 Hemer

☎ 0 23 72/965-0 ☎ 0 23 72/6 1240 ✉ info@giersch.de 🌐 www.giersch.de

### Declaration of Conformity for Oil Burners

We, Enertech GmbH, Adjutantenkamp 18 in D-58675 Hemer declare under our responsibility that

oil burner type      **R20,**  
                                 **R20-V and**  
                                 **R20-AE**

are conform with the regulations of these directives

MD2006/42/EC  
EMC2004/108/EC  
BED92/42/EEC  
LVD2006/95/EC  
ErP2009/125/EG

und are marked with:



EN 267 report OB 2912016T1 TÜV Rheinland Energy GmbH

Hemer, 12.01.2024

Dr. Josef Becker  
Geschäftsführer



Wärme für die Zukunft.

Giersch GmbH | Adjutantenkamp 18 | 58675 Hemer

☎ 0 23 72/965-0 📠 0 23 72/6 1240 📧 info@giersch.de 🌐 www.giersch.de

## Declaration of Conformity for Oil Burners

We, Enertech GmbH, Adjutantenkamp 18 in D-58675 Hemer declare under our responsibility that

oil burner type **R20-ZS-L**

are conform with the regulations of these directives

MD2006/42/EC

EMC2004/108/EC

BED92/42/EEC

LVD2006/95/EC

und are marked with:



EN 267 report OB 2912016T1 TÜV Rheinland Energy GmbH

Hemer, 12.01.2024

Dr. Josef Becker  
Geschäftsführer



Wärme für die Zukunft.

Giersch GmbH | Adjutantenkamp 18 | 58675 Hemer

☎ 0 23 72/965-0 ☎ 0 23 72/6 1240 ✉ info@giersch.de 🌐 www.giersch.de

## Declaration of Conformity for Oil Burners

We, Enertech GmbH, Adjutantenkamp 18 in D-58675 Hemer declare under our responsibility that

oil burner type      **R30**

are conform with the regulations of these directives

MD2006/42/EC

EMC2004/108/EC

BED92/42/EEC

LVD2006/95/EC

ErP2009/125/EG

und are marked with:



EN 267 report OB 29220161 TÜV Rheinland Energy GmbH

Hemer, 12.01.2024

Dr. Josef Becker  
Geschäftsführer



## Burner overall dimensions / boiler connection dimensions (All dimensions in mm)

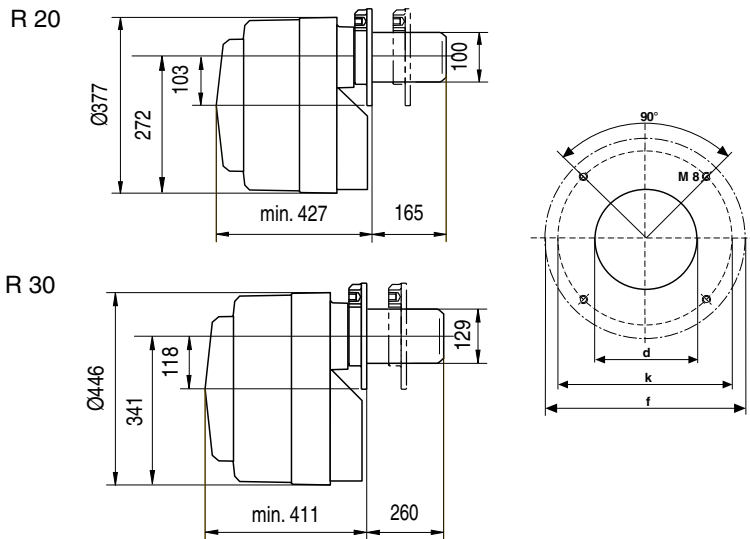

	R 20	R 30
Pipe outer dia. d	102	130
Hole circle dia. k	170(140-180)	170-200
Outside dia. f	194	220

## Working ranges

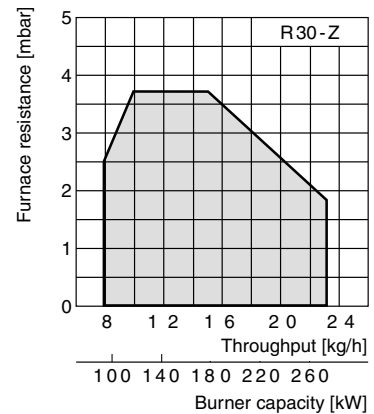
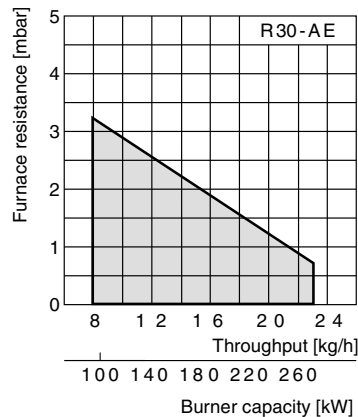
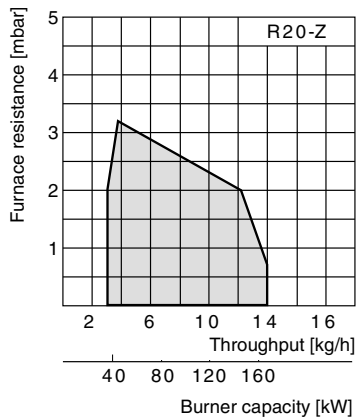
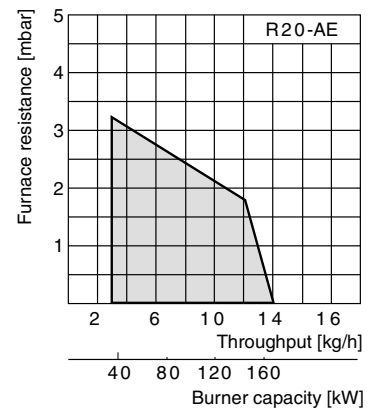
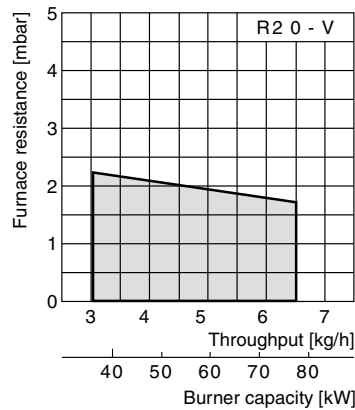
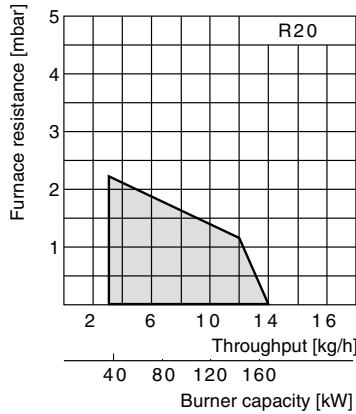

All information in this technical documentation as well as the drawings, photos and technical descriptions placed at your disposal remain our property and may not be duplicated without our written permission given in advance.  
Subject to alterations.

# GIERSCH

Giersch GmbH • Brenner und Heizsysteme  
Adjutantenkamp 18 • D-58675 Hemer •  
Telephone 02372/965-0 • Fax 02372/61240  
E-mail: info@giersch.de • Internet: <http://www.giersch.de>

