

GG10-LN

Issued April 2024

In the interests of continuous product improvement, technical specifications are subject to change without prior notice!

Gas



Contents

Overview	3
General information	3
Scope of supply and electrical ratings	3
Operating instructions	3
Instruction of operating personnel	3
Maintenance and customer service	3
Key for code designation	4
Technical specifications	4
Installation	5
Installing the flange and burner	5
Installing the gas ramp	5
Service position	6
Connecting to the power supply	7
Function	8
Control unit LME	8
Start-up	11
Air flow setting	11
Adjusting the mixing head	11
Adjusting the ignition electrode	12
Adjusting the gas ramps.....	13
Adjustment tables.....	15
Calculation principle for gas burner adjustment	17
Service instructions/dimensions	19
Flame control using ionisation electrode	19
Measuring the ionisation current	19
Servicing the air pressure monitor.....	19
Wiring diagram	20
Exploded drawing.....	21
Spare parts list	22
Declaration of conformity for the forced-air gas burner	23
Burner dimensions / boiler connection dimensions.....	24
Working ranges	24

Overview

General information

Installation of a gas-fired heating system must be performed in accordance with the applicable regulations and guidelines. It is therefore the duty of the installer to be familiar with all applicable regulations and requirements. Installation, start-up and maintenance must be performed with utmost care.

The burner must not be operated in rooms with high levels of air humidity (laundry rooms), dust or corrosive vapours. The boiler room must be ventilated accordingly with ventilation air. The ENERTECH GG10-LN series of gas burners are suitable for burning natural gas or liquefied petroleum gas in accordance with DIN EN 437 and comply with the European Standard DIN EN 676.

Scope of delivery and connection data

Before installing the ENERTECH gas burner, please check the scope of delivery.

Scope of delivery:

Burner, sliding flange and gasket, 4 retaining screws, separate operating instructions, technical information, one 7-pin connector, gas ramp and gasket.

Gas installation and commissioning are subject to the applicable national regulations, e.g. in Germany the Technical Regulations of the DVGW (DVGW-TRGI).

The following must be observed for Switzerland: SVGW Gas Provisions G1, G3: Gas installation EKAS Form.

1942: Liquefied gas regulation, Part 2 Regulations of cantonal authorities (e. g. fire department regulations).

The gas pipe must be designed to conform to the flow rate and the available gas flow pressure and routed with the lowest pressure loss over the shortest distance to the burner.

The loss of gas pressure via the gas ramp and the burner, and the resistance on the fuel gas side of the heat generator must be less than the connection flow pressure.



Caution !
Observe the through-flow direction of the gas ramp.

Operating instructions

The operating instructions together with this technical information leaflet must be displayed in a clearly visible position in the boiler room. It is essential to enter the address of the nearest customer service centre in the operating instructions.

Instruction of operating personnel

Faults are often caused by operator error. The operating personnel must be properly instructed in how the burner works. In the event of recurring faults, Customer Service should be notified.

Maintenance and customer service

The complete system should be checked once a year for correct functioning and leaks by a representative of the manufacturer or other suitably qualified person.

We accept no liability for consequential damage in cases of incorrect installation or repair, the fitting of non-genuine parts or where the equipment has been used for purposes for which it was not intended.

Key for code designation

GG10/1-N-LN

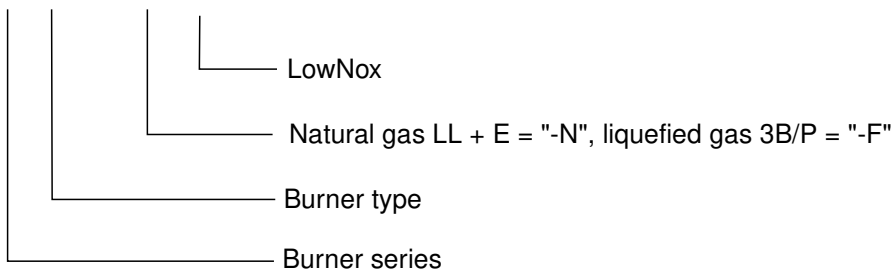

Technical specifications

Technical specifications	Burner type	
	GG10/1-LN	GG10/2-LN
Burner output	12 - 60 kW	20 - 90 kW
Gas type	Natural gas LL + E = "-N", liquefied gas 3B/P = "-F"	
Gas input pressure with MBC65 1/2"	65 mbar	
Gas input pressure MBC120 3/4"	360 mbar	
Voltage	1 / N / PE ~ 50 Hz / 230 V	
Current consumption start max. / operation	1.9 A / 0.8 A	
Electric motor	90	
Ignition transformer	35 mA; 8 kV rms.	
Control unit	LME11	
Weight	8 kg	
Noise emission	≤ 59 dB(A)	
Emission class	5	
NOx limit value	≤ 56 mg/kWh	

Installation

Mounting the flange and burner

1. Mount the flange base and gasket onto the boiler:

- Observe "top" mounting position,
- Tighten M8 screws including U-washer,
- The upper flange part (half shells) must be fitted to the burner tube in advance and the clamping screws must be attached.



During the assembly procedure, ensure that the 0° display on the flange top aligns with the "top" display on the flange base.

2. Installing the burner:

- To mount the burner, engage the burner housing **in the retaining lugs by rotating it clockwise.**
- Tighten the clamping screw. Make sure that the conical nipple is inserted in the lower part of the flange correctly.

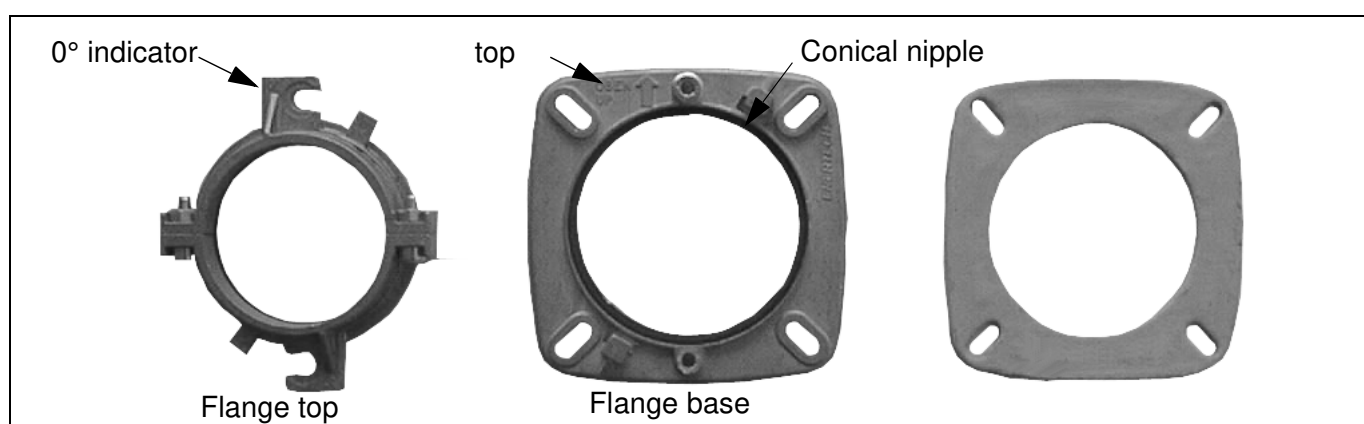

Mounting the gas ramp!

Installing the gas ramp	
Installation position for vertical line	as desired
Installation position for horizontal line	tilted up to max. 90° to left or right, not overhead
Minimum distance to masonry	20 mm

Installation position MBC-...

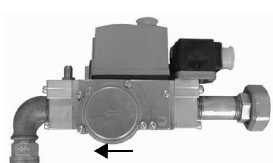

- Remove plastic protective plug.
- Mount the screw connections with enclosed seals.
- Observe the installation position.
- Check connecting point of gas ramp with non-corrosive foaming agent for leaks and vent the gas pipe.
- When venting, use a hose to discharge the gas safely to the atmosphere.



The gas supply line and gas assembly must not exert tensile, compression or torsional forces on the burner, since this can otherwise adversely affect operational safety.

In Germany, observe DVGW-TRGI 1986/96 Section 7, TRF 1988, DIN 4756 and local regulations

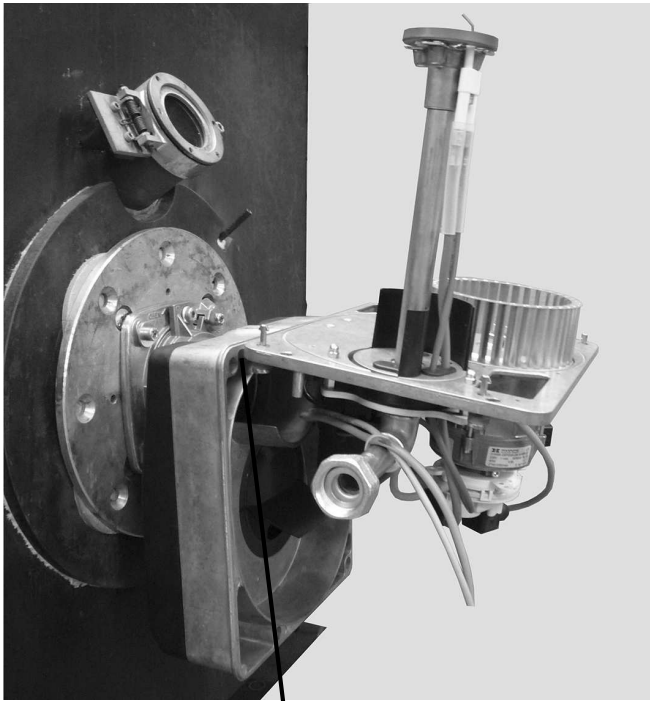

Service position



Risk of injury by fan impeller on activation in service position.

Release quick-release locks (4 x) and detach base plate. Place the keyhole openings in the base plate onto the socket head cap screws of the housing and lock them into place.



Connect to power supply

- Deenergise the system. Main switch "OFF".
- Check the polarity of all connectors.
- Connect the plug unit as indicated in the connection diagram. Lay the flexible control line so that the boiler door remains swivellable.
- Insert the coded cube connectors to the gas pressure monitor and to the solenoid valves and use a screw to fasten.
- If plug X11 is wired as shown the terminal diagram, check that the pins are correctly assigned..
- Connect the 7-pin plug of the boiler controller (X11) to the black-brown socket on the burner (X12).
- The power cord of the 7-pin connecting plug X11 must be fused with a slow-acting fuse rated for max. 6.3 A or a quick-acting fuse rated for max. 10 A.

Connection diagram

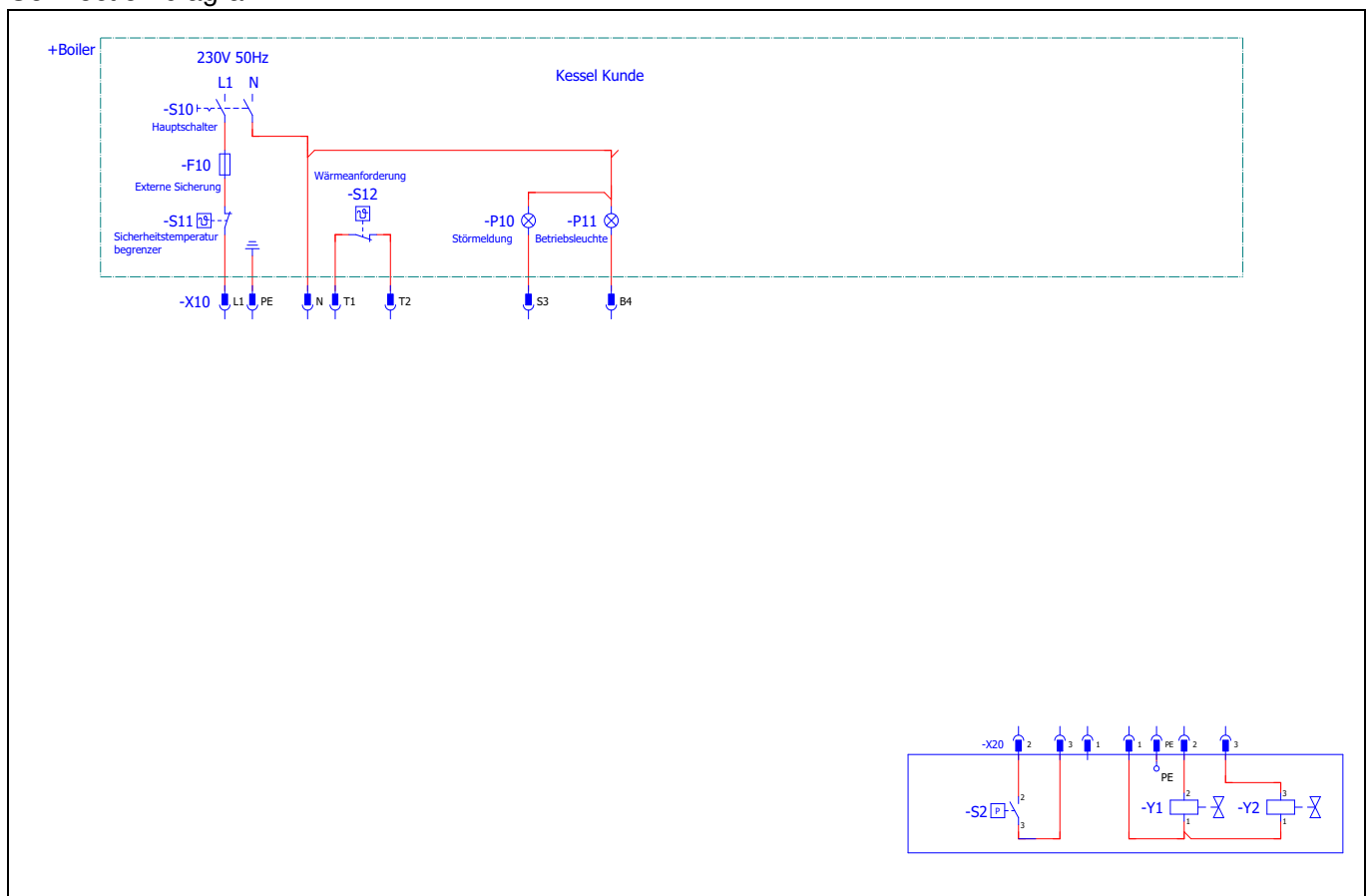

Function



Function test of control box

Danger of fatal injury from electric shocks!



Disconnect electrical cable from power supply before carrying out any work on live parts!

Troubleshooting may only be carried out by authorised and trained personnel! (Remote) Unlocking may only be carried out by an authorised specialist.

Carry out the following checks after commissioning and maintenance of the burner.

Burner start with interrupted lines to flame sensor:

- Interrupt the line to the flame sensor and start the burner.
At the end of the safety time, the control unit performs a failure shut-down after three repetitions.
- Re-establish the connection.

Burner operation with loss-of-flame simulation:

- Turn the dial of the gas pressure monitor to the minimum value (see Page 13).
- Start the burner.
- Close the ball valve during operation.
After loss of flame, the control unit performs a failure shut-down after three repetitions.
- Turn the dial of the gas pressure monitor to the initial value.

Burner operation with loss of air pressure:

- Pull of the air hose at the "+" input of the air pressure monitor during operation.
The control unit performs a failure shut-down.
- Attach the air hose to the air pressure monitor again.

Safety and switching functions

If, at the end of the safety time, no flame forms, or there is a loss of flame during operation, a maximum of three repetitions can be carried out for each control circuit; otherwise a failure shut-down is performed. If a flame signal is given during the pre-ventilation phase, a failure shut-down will occur immediately. The position of the air pressure monitor is continuously checked. There can be no start-up if it is not in its neutral position. If the NO contact does not close or reopens during the pre-ventilation phase, a failure shut-down will occur. The air pressure monitor contact and the valves close if the air flow is insufficient during operation. The device goes into failure mode.

Display during commissioning

Color code table for multi-color signal lamp		
Status	Color code	Color
Waiting time (tw), other Waiting states	○.....	OFF
Air pressure switch waiting phase, Pre-ventilaton	●.....	Yellow
Ignition phase, ignition controlled	○●○●○●○●○●	Yellow flashing
Operation, flame OK	■.....	Green
Operation, flame poor	○■○■○■○■○■	Green flashing
External light on burner start	■▲■▲■▲■▲■▲	Green-red
Undervoltage	●▲●▲●▲●▲●▲	Yellow-red
Fault, alarm	▲.....	Red
Fault code output, see fault code table	○▲○▲○▲○▲○▲○	Red flashing
Interface diagnostics	▲▲▲▲▲▲▲▲▲▲▲▲	Red flickering light

Key:

- Permanent
- OFF
- ▲ Red
- Yellow
- Green

Troubleshooting diagnostics

After failure shutdown, the red signal lamp lights up permanently. In this state, the visual troubleshooting diagnostics can be activated according to the fault code table by actuating the unlocking key **> 3 seconds**. Actuate the unlocking key again for **>3 seconds** to activate the interface diagnostics. The interface diagnostics operates only when the unlocking key adapter AGK20... is not attached. If the interface diagnostics is activated unintentionally (indicated by a weak flickering of the signal lamp in red), it can be switched off again by actuating the unlocking key **>3 seconds**. The correct moment for switchover is signaled by a yellow light pulse.

Fault code table

Flashing code "red" of the fault signal lamp (LED)	Alarm at terminal 10	Possible causes
Flashes 2 x	On	No flame forms at the end of the safety time (TSA) - Defective or soiled fuel valves - Defective or soiled flame sensor - Poor burner setting, no fuel - Defective defekte ignition device
Flashes 3 x	On	Error air pressure monitor (LP) - Air pressure failure after specified time (t10) - Air pressure switch (LP) welded in idle position
Flashes 4 x	On	External light on burner start
Flashes 5 x	On	Time monitoring air pressure monitor (LP) - Air pressure monitor (LP) welded in working position - Fault during seal check (only in connection with leak check (LDU11..))
Flashes 6 x	On	Free
Flashes 7 x	On	Too frequent loss of flame during operation (repetition limit) - Defective or soiled fuel valves - Defective or soiled flame sensor - Defective burner setting
Flashes 8 x	On	Free
Flashes 9 x	On	Free
Flashes 10 x	Off	Wiring fault or internal error, output contacts, other fault
Flashes 14 x	On	CPI contact not closed

The control outputs are deenergised during troubleshooting diagnostics.

- The burner remains switched off,
- The entrnal fault display remains deenergised
- Fault signal alarm (AL) at terminal 10 according to fault code table.

Unlock to exit the troubleshooting diagnostics and switch the burner on again.

Press the unlocking key approx. **1 s (< 3 s)**.

Start-up

The burner can be put into operation once the gas and electrical installation and assembly work has been completed.

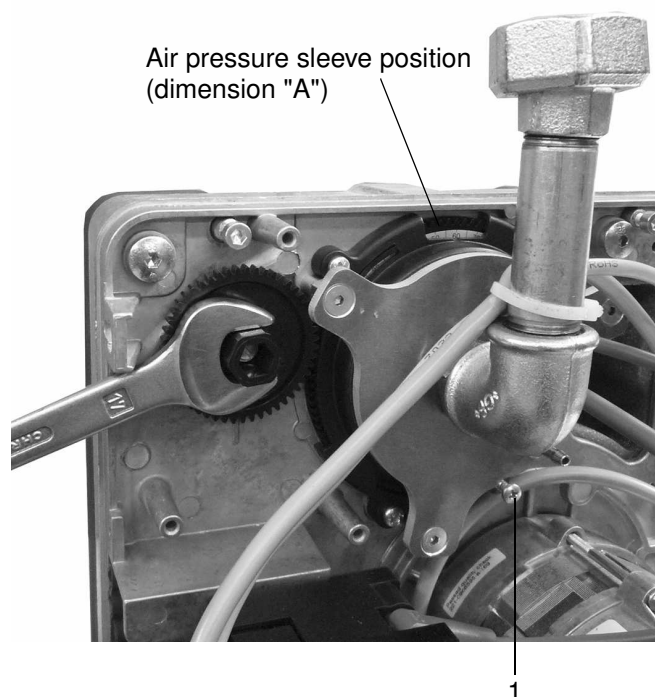

Air regulating sleeve

The scale serves as an orientation aid to facilitate adjustment of the air quantity. Use a hexagon key (SW17) to modify the air quantity according to performance in accordance with the setting table (see page 15 ff). The values in the table of settings can be read off directly at the scale.

If there is overpressure in the combustion chamber, set the value higher; if there is underpressure, the value must be reduced.

Readjustment is necessary in any case on account of the type of plant.

After setting the combustion values, the air regulating sleeve must be fixed with screw 1 to prevent misalignment.

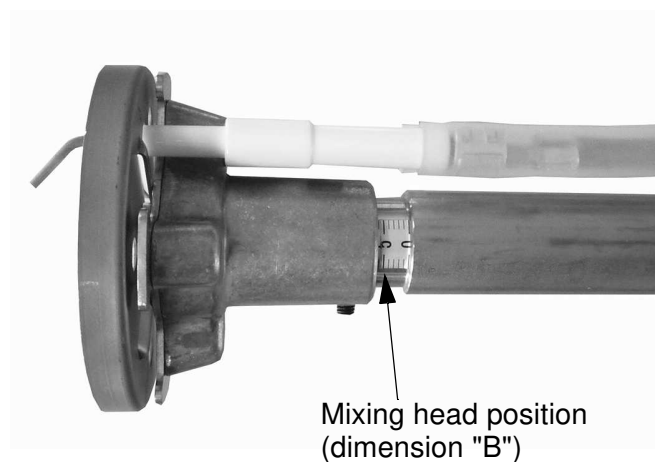

Adjustment of the mixing head

Set the position of the mixing head according to burner output in accordance with the setting table on page 15 ff.

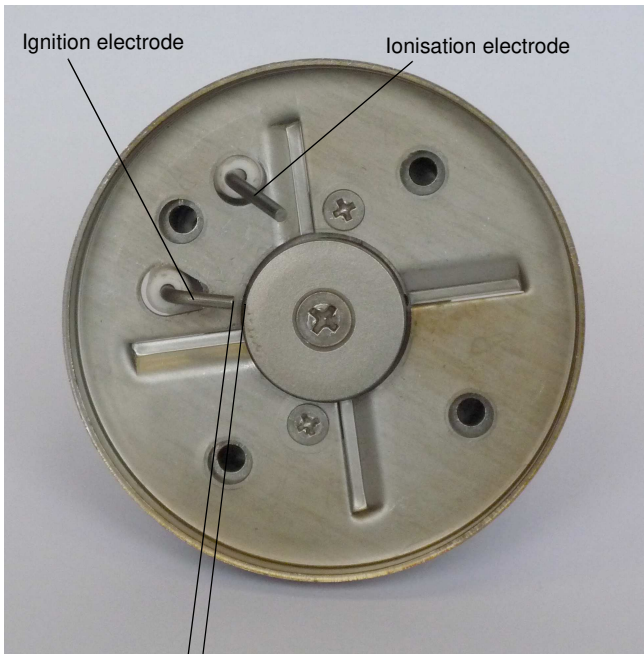

Adjusting the ignition electrode

The electrode is set at the factory. The dimensions are included for checking purposes.

Setting the gas ramps

Remove the gas flow cap on the gas ramp upwards prior to setting.

The Allen key (2 mm) for setting is located in the cap.

MBC65 1/2"

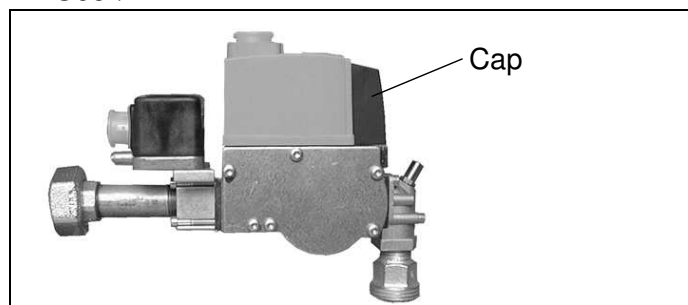

MBC120 3/4"

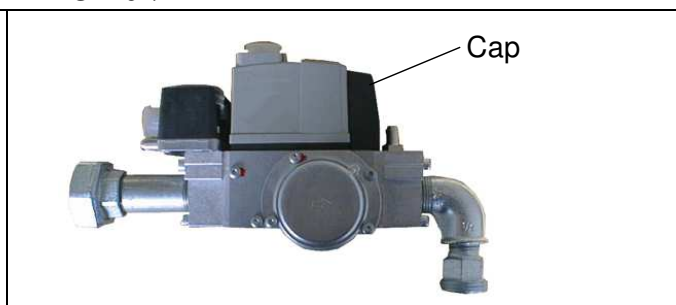

MBC65 1/2"

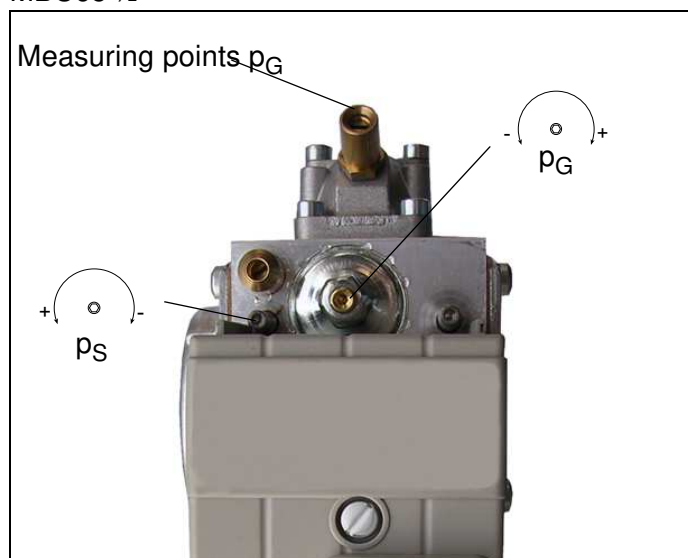

MBC120 3/4"

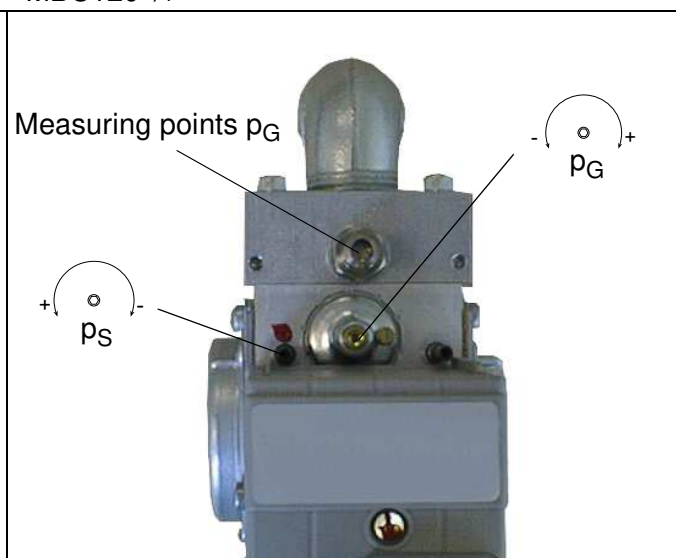

To measure the gas pressure, open the measuring points and connect the pressure gauge.

p_S = Starting gas

p_G = Gas pressure gauge

Perform commissioning steps 1 bis 8 using the plant data analogous to the setting example.

Exhaust gas values	Natural gas LL+E	Liquefied gas propane 3P
O ₂ content	3.5-5.0%	
CO ₂ content	9-10%	10.5-11.5%



Setting the gas pressure monitor to Minimum (5 mbar at MBC65 1/2")

Start-up

Adjustment example, GG10/1 to 30 kW, natural gas E:

1. Set the position of the mixing head to dimension "B" 5 mm (see Fig. p. 11, Setting the mixing head).
2. p_S , p_G and dimension "A" remain unchanged.
3. Start the burner.
4. To achieve the desired performance (30 kW in this case), p_G and dimension "A" must be changed gradually from the factory setting.
Set p_G to approx. 5.1 mbar and dimension "A" to approx. 35°.
5. Turn p_S up (left) to 19 mm
6. Start the burner again and correct the settings if necessary.
7. Close the measuring points
8. Check the gas pressure controller after start-up.
Close the ball valve slowly. Close the ball valve slowly, the burner must switch off without triggering a fault.

MBC65 1/2"

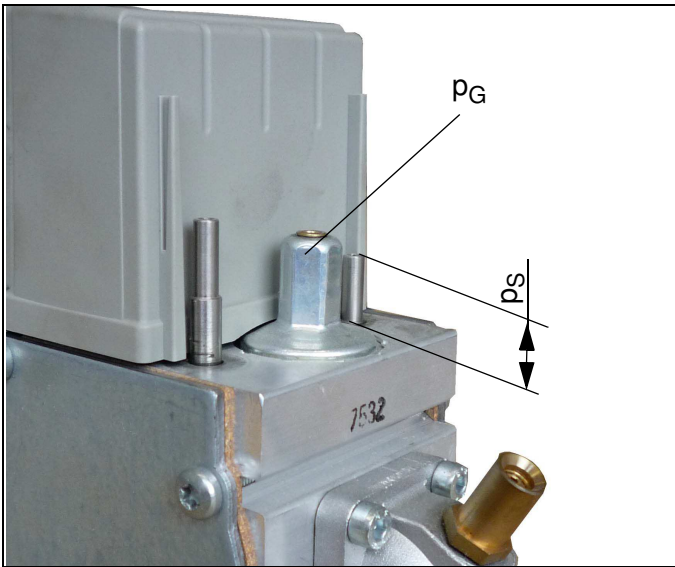

MBC120 3/4"

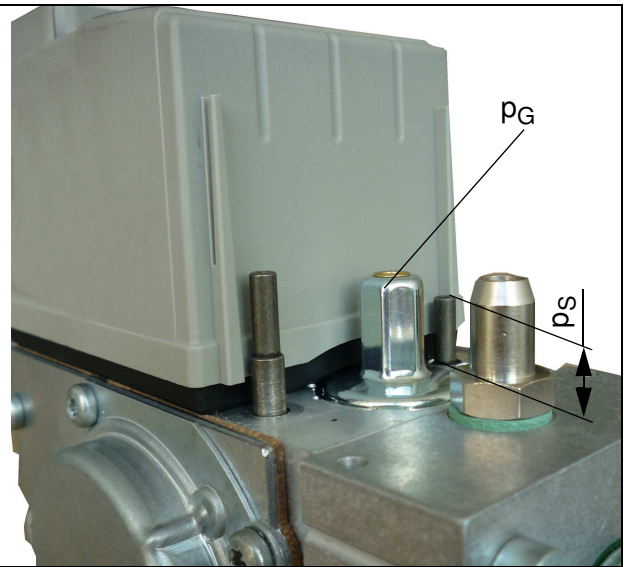

The setting screw p_G does not have a stop.

To restore the factory settings for a modified gas ramp, you must observe the following:

GG10/1-LN with MBC-65

- 1 Turn p_G 10 x left
- 2 p_S 18 mm
- 3 Dimension "A" 24°
- 4 Start the burner
- 5 Set p_G to 2.3 mbar

GG10/2-LN with MBC-120

- 1 Turn p_G 10 x left
- 2 p_S 18 mm
- 3 Dimension "A" 35°
- 4 Start the burner
- 5 Set p_G to 3.9 mbar

Adjustment tables



The values given in the tables are only guide values for start-up. The system settings required in each case must be redefined if values such as boiler output, calorific value and altitude deviate.

A correction is required in any case.

On first commissioning and after each adjustment, a combustion check must be carried out.

GG10/1-N-LN				Natural gas LL: $H_{i,n} = 9.3$ [kWh/m ³]		
Burner output [kW]	Boiler output $\eta = 92\%$ [kW]	Air regulating sleeve Position Dimension "A" [°]	Mixing head Position Dimension "B" [mm]	Gas nozzle pressure p_G [mbar]	Starting gas p_S [mm]	Gas flow rate [m ³ /h]
12	11	10	5	1.0	16	1.3
15	14	18	5	1.7	18	1.7
20*	18	24	5	3.0	18	2.2
25	23	29	5	4.6	18	2.8
30	28	35	5	6.6	19	3.3
41	38	66	5	11.6	22	4.5
45	41	72	5	14.0	22	5.0
40	37	45	0	8.1	22	4.4
51	47	64	0	12.6	22	5.7
60	55	125	0	16.0	22	6.7

GG10/1-N-LN				Natural gas E: $H_{i,n} = 10.4$ [kWh/m ³]		
Burner output [kW]	Boiler output $\eta = 92\%$ [kW]	Air regulating sleeve Position Dimension "A" [°]	Mixing head Position Dimension "B" [mm]	Gas nozzle pressure p_G [mbar]	Starting gas p_S [mm]	Gas flow rate [m ³ /h]
12	11	10	5	0.8	16	1.2
15	14	18	5	1.3	18	1.5
20*	18	24	5	2.3	18	2.0
25	23	29	5	3.5	18	2.5
30	28	35	5	5.1	19	3.0
41	38	66	5	8.9	22	4.1
45	41	72	5	10.8	22	4.5
40	37	45	0	6.2	22	4.0
51	47	64	0	9.7	22	5.1
60	55	125	0	12.3	22	5.9

GG10/1-F-LN				Liquid gas: $H_{i,n} = 25.89$ [kWh/m ³]		
Burner output [kW]	Boiler output $\eta = 92\%$ [kW]	Air regulating sleeve Position Dimension "A" [°]	Mixing head Position Dimension "B" [mm]	Gas nozzle pressure p_G [mbar]	Starting gas p_S [mm]	Gas flow rate [m ³ /h]
16	15	18	5	1.0	16	0.6
24*	22	29	5	2.3	18	1.0
30	28	35	2	2.7	19	1.2
35	32	45	2	3.7	20	1.4
40	37	45	0	3.9	22	1.6
50	46	60	0	6.0	22	2.0
65	60	125	0	10.0	22	2.6

* Factory setting

GG10/2-N-LN				Natural gas LL: $H_{i,n} = 9.3$ [kWh/m ³]		
Burner output [kW]	Boiler output $\eta = 92\%$ [kW]	Air regulating sleeve Position Dimension "A" [°]	Mixing head Position Dimension "B" [mm]	Gas nozzle pressure p_G [mbar]	Starting gas p_S [mm]	Gas flow rate [m ³ /h]
21	19	22	5	1.2	16	2.3
35*	32	35	5	3.9	18	3.9
50	46	51	5	7.6	18	5.5
36	33	31	2	2.8	18	4.0
50	46	40	2	5.1	20	5.5
65	60	55	2	8.3	20	7.2
65	60	60	0	8.0	22	7.2
80	74	80	0	11.4	22	8.9
90	83	125	0	15.4	22	10.0

GG10/2-N-LN				Natural gas E: $H_{i,n} = 10.4$ [kWh/m ³]		
Burner output [kW]	Boiler output $\eta = 92\%$ [kW]	Air regulating sleeve Position Dimension "A" [°]	Mixing head Position Dimension "B" [mm]	Gas nozzle pressure p_G [mbar]	Starting gas p_S [mm]	Gas flow rate [m ³ /h]
21	19	22	5	0.9	16	2.1
35*	32	35	5	3.0	18	3.5
50	46	51	5	5.8	18	5.0
36	33	31	2	2.2	18	3.6
50	46	40	2	3.9	20	5.0
65	60	55	2	6.4	20	6.4
65	60	60	0	6.1	22	6.4
80	74	80	0	8.8	22	7.9
90	83	125	0	11.8	22	8.9

GG10/2-F-LN				Liquid gas: $H_{i,n} = 25.89$ [kWh/m ³]		
Burner output [kW]	Boiler output $\eta = 92\%$ [kW]	Air regulating sleeve Position Dimension "A" [°]	Mixing head Position Dimension "B" [mm]	Gas nozzle pressure p_G [mbar]	Starting gas p_S [mm]	Gas flow rate [m ³ /h]
22	20	21	5	1.0	18	0.9
35*	32	36	5	2.8	18	1.4
40	37	33	2	2.8	20	1.6
65	60	55	2	7.2	20	2.6
75	69	70	0	8.7	22	3.0
85	78	100	0	10.5	22	3.4
95	87	125	0	13.2	22	3.8

* Factory setting

Calculation principle for gas burner adjustment

The values given in the tables are setting values for start-up.

The necessary system adjustment must be newly determined in each case.

General:

The calorific value ($H_{i,n}$) of fuel gases is generally specified for the normal state (0°C, 1013 mbar).

Natural gas E $H_{i,n} = 10.4 \text{ kWh/m}^3$

Natural gas LL $H_{i,n} = 9.3 \text{ kWh/m}^3$

Liquefied gas PB $H_{i,n} = 25.89 \text{ kWh/m}^3$

Gas meters measure the volume of gas in the operational state.

Gas flow determination:

To allow the heat generator load to be adjusted correctly, the gas flow rate must be determined in advance.

Example:

Height above sea level	230 m
Atmospheric pressure B (according to table)	989 mbar
Gas pressure P_G at meter	20 mbar
Gas temperature ϑ_G	16°C
Boiler rating Q_n	30 kW
Efficiency η_K (assumed)	92%
Calorific value $H_{i,n}$	10.4 kWh/m ³

Gas flow in standard state (V_n)¹

$$V_n = \frac{Q_n}{\eta_K \times H_{i,n}} = \frac{30 \text{ kW}}{0,92 \times 10,4 \frac{\text{kWh}}{\text{m}^3}} = 3,1 \frac{\text{m}^3}{\text{h}}$$

Gas flow in operating state (V_B)

$$V_B = \frac{V_n}{f} = \frac{3,1 \frac{\text{m}^3}{\text{h}}}{0,94} = 3,3 \frac{\text{m}^3}{\text{h}}$$

Conversion factor (f)

$$f = \frac{B + P_G}{1013} \times \frac{273}{273 + \vartheta_G}$$

Annual average air pressure

Average geodetic altitude of the supply region above sea level [m]	from		1	51	101	151	201	251	301	351	401	451	501	551	601	651	701
	to	0	50	100	150	200	250	300	350	400	450	500	550	600	650	700	750
Annual average of air pressure	(mbar)	1016	1013	1007	1001	995	989	983	977	971	965	959	953	947	942	936	930

Legend:

Q_n = boiler output [kW]

η_K = efficienc [%]

$H_{i,n}$ = lower standard calorific value [kWh/m³]

f = conversion factor

B = atmospheric pressure [mbar]

p_G = gas pressure at gas meter [mbar]

ϑ_G = gas temperature at gas meter [°C]

Start-up

Flow measurement

Determining flow duration at gas meter..

Calculated flow duration in seconds t_{spec} for a flow volume of 200 litres (corresponding to 0.2 m³) for the example given above is::

$$V_B = 3.3 \text{ m}^3/\text{h}$$

$$t_{\text{soll}} = \frac{0,2 \text{ m}^3 \times 3600 \frac{\text{s}}{\text{h}}}{V_B \left[\frac{\text{m}^3}{\text{h}} \right]} = \frac{720 \text{ m}^3 \frac{\text{s}}{\text{h}}}{V_B \left[\frac{\text{m}^3}{\text{h}} \right]} = \frac{720 \text{ m}^3 \frac{\text{s}}{\text{h}}}{3,3 \frac{\text{m}^3}{\text{h}}} = 218 \text{ s}$$

Gas flow setting

Measured flow duration in seconds [s]	Measures
Greater than calculated flow duration t_{set}	Increase gas flow
Less than calculated flow duration t_{set}	Reduce gas flow
Equal to calculated flow duration t_{set}	Gas flow achieved

Service instructions/dimensions

Flame control using ionisation electrode

If an AC current is applied between the burner and the ionisation rod, a DC current flows due to the rectifying effect of the flame. This ionisation current forms the flame signal and is amplified and passed to control box. A flame cannot be faked because the rectifying effect no longer works if there is a short-circuit between the sensor electrode and the burner.

Measuring the ionisation current

During commissioning and maintenance of the burner or after a fault message from the control unit, the measure ionization current. To do this, the plug connection in the ionization cable is disconnected and a measuring device for current measurement is connected in series. Measuring range 0...200 μ A DC. The measurement must be carried out directly after the post-ignition time during the safety time! The ionization current must be at least 5 μ A. Values **below 5 μ A lead to unsafe operation (fault lamp flashes green) or directly to a fault.** In this case, the inside of the ionizing bar and the burner tube must be cleaned. Bend the ionizing bar if necessary. If the ionizing bar is defective, replace the electrode. Possibly reverse the polarity of the ignition transformer. Check cable for moisture and dry if necessary.



Servicing the air pressure monitor

- Detach the silicone connecting hose and clean, check the switching function.
- Replace the air pressure monitor if switching function is no longer working properly.

To do so:

- Switch off the burner voltage
Disconnect (7-pin connector X11).
- Unscrew the cover.
- Disconnect the electrical connectors.
- Release the retaining screws on motor.
- Reassemble in the reverse order..

P1

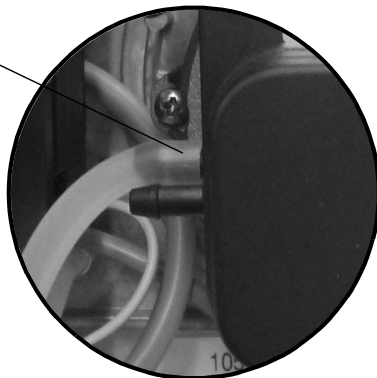

"P1" marks the pressure measuring connection for the silicone hose!

Wiring diagram

SP_1-1057.1

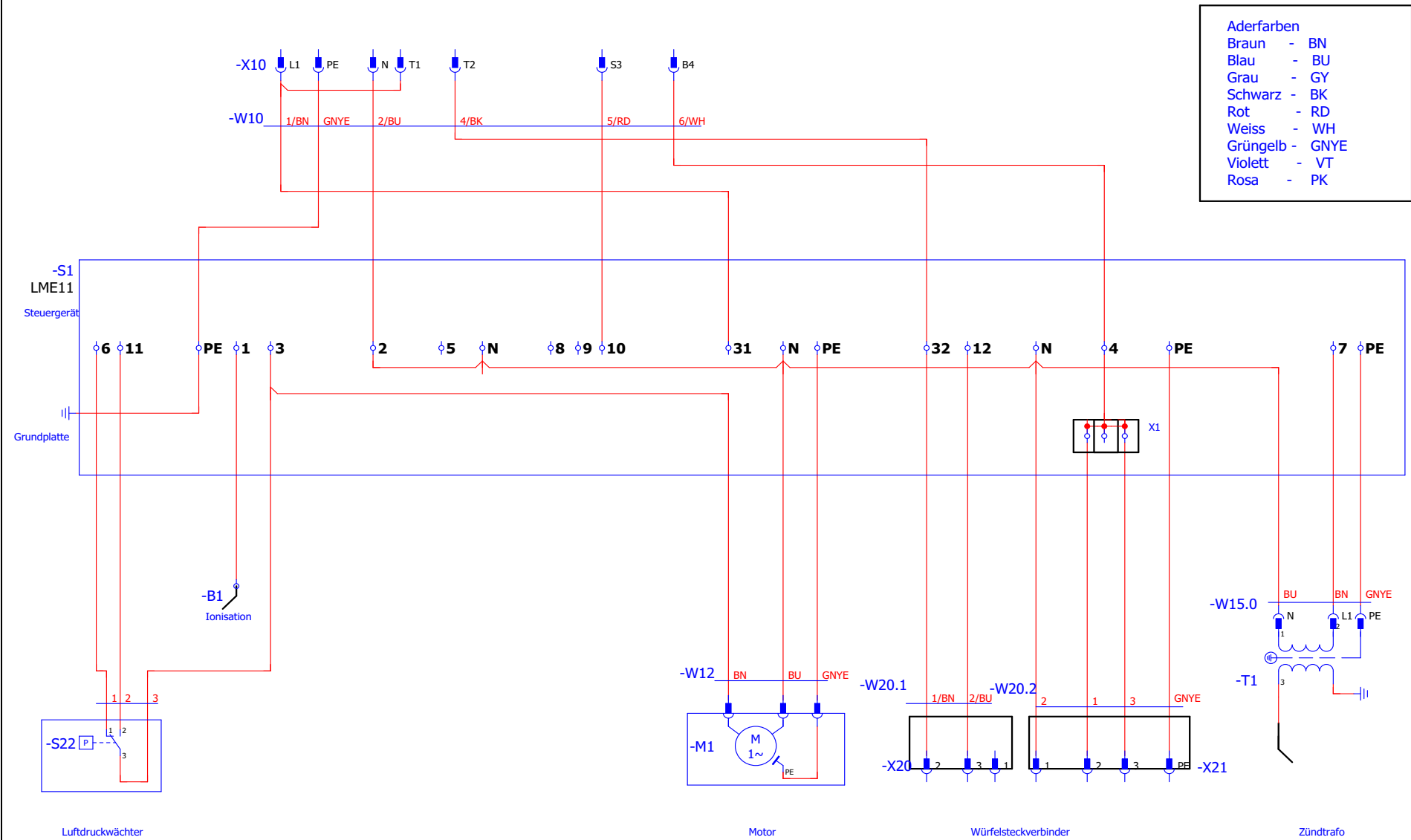

20

Exploded drawing

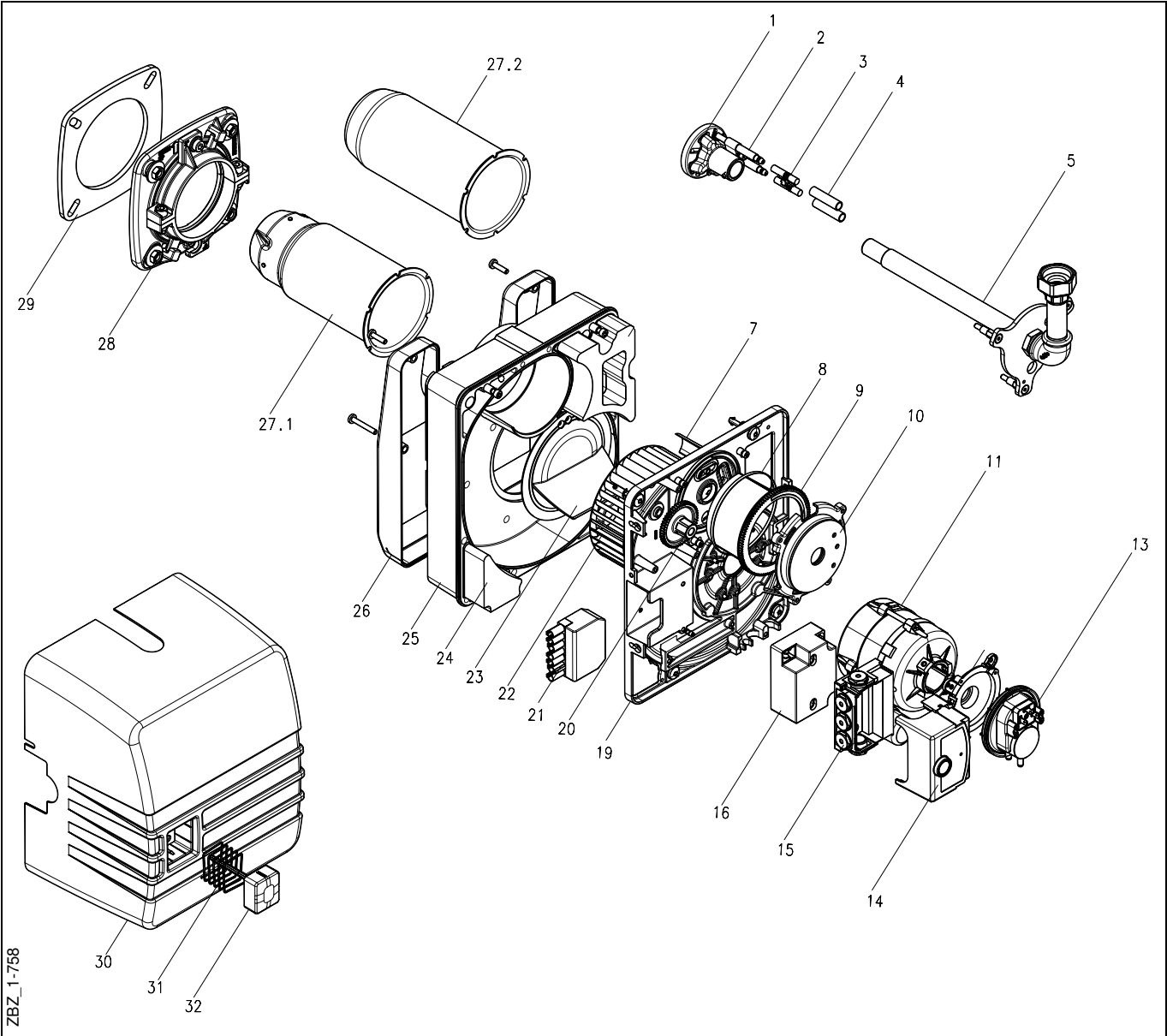

Spare parts list

Seq. No.	Designation	VE	Order no.
1	Gas mixer head GG10/1-N-LN, complete, with baffle plate and electrode	1	47-90-25313
1	Gas mixer head GG10/2-N-LN, complete, with baffle plate and electrode	1	47-90-25314
1	Gas mixer head GG10/1-F-LN, complete, with baffle plate and electrode	1	47-90-25315
1	Gas mixer head GG10/2-F-LN, complete, with baffle plate and electrode	1	47-90-25316
2	Ignition electrode	1	47-90-25296
3	Ignition cable with angled plug	1	47-90-24835
3	Ignition cable with angled plug 100 mm extended	1	47-90-26740
3.1	Ionisation cable with socket unit	1	44-90-20634
3.1	Ionisation cable with socket unit 100 mm extended	1	47-90-26328
4	Silicon hose 10 x 1 x 80 lg.	1	47-90-22466
5	Adapter plate with gas connection, complete	1	47-90-29045
5	Adapter plate with gas connection, complete 100 mm extended	1	47-90-29045-01
7	Airflow rectifier	1	47-90-22489-01
8	Guide ring	1	47-90-26918
9	Air regulatig sleeve with scale	1	47-90-21777
10	Spring lid with foeam rubber seal	1	47-90-29049
11	Motor 90 W	1	31-90-11582
13	Air pressure monitor DL5E 32Z 1,5 mbar	1	47-90-29266-01
14	Control unit LME11	1	47-90-29190
15	Control unit base GG10 LME11	1	47-90-29467
16	Ignition transformer	1	47-90-24469
19	Pre-assembled base plate	1	47-90-25287
20	Pinion	1	47-90-21884
21	7-pin socket with cable	1	47-90-22072
22	Ventilator wheel Ø133 x 52	1	47-90-21729
24	Filler insulation	1	47-90-22105
23	Inlet nozzle item 1	1	47-90-21774-01
25	Housing, complete with suction silencer	1	47-90-21770
26	Intake damper cpl.	1	47-90-21771
27.1	Burner tube GG10/1-LN	1	47-90-24757
27.2	Burner tube GG10/2-LN	1	47-90-24758
27.2	Burner tube GG10/2-LN 100 mm extended	1	47-90-24758-01
28	Assembly kit Enertech flange 90 mm	1	47-90-25269
-	O-ring ID 110 x 4	1	47-90-25242
29	Flange seal 152 x 152 mm	1	47-90-24429
30	Burner cover, complete with reset button	1	47-90-21765-01
31	Rectangular spring	1	47-90-26966
32	Interference-suppression button, short	1	47-90-21767
-	Working ranges 2 x Ø4,5	1	47-90-25129
-	Transformer earthing cable	1	47-90-25289
-	Replacement set of quick release fasteners G, GL10 / GB / GL20 / GG20	1	47-90-29352
-	Combustion chamber pressure measuring tube for KEV (CG and MBC)	1	47-90-30200

Declaration of conformity for the forced-air gas burner



Wärme für die Zukunft.

Giersch GmbH | Adjutantenkamp 18 | 58675 Hemer

☎ 0 23 72/965-0 ☎ 0 23 72/6 1240 ✉ info@giersch.de 🌐 www.giersch.de

Declaration of Conformity for Gas Burners

We, Giersch GmbH, Adjutantenkamp 18 in D-58675 Hemer declare under our responsibility that

gas burner type **GG10/...**

is conform with the regulations of these directives

MD2006/42/EG

EMV2014/30/EG

GAD 2016/426/EG

MCP2015/2193/EU

RoHS 2011/65/EU

DIN EN 676

and is marked with:



CE-0085

Hemer, 12.01.2024

Dr. Josef Becker
Managing Director

Burner dimensions / boiler connecting dimensions (all dimensions are in mm)

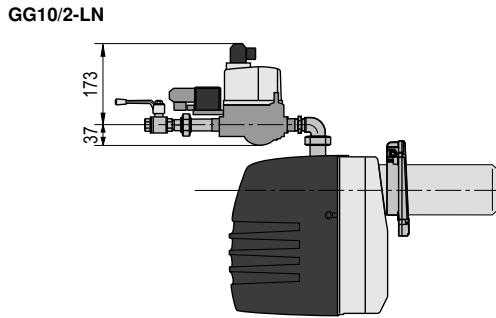
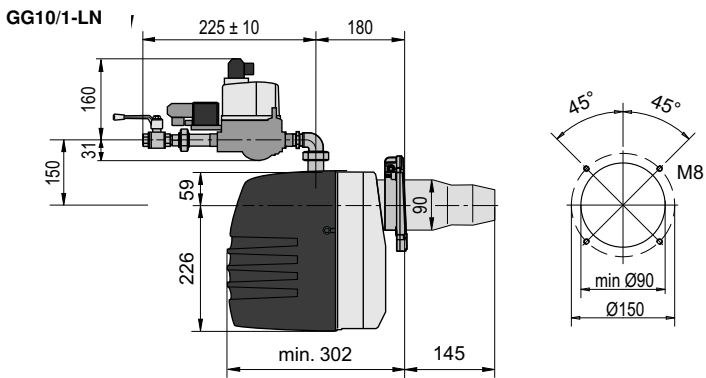

Working ranges

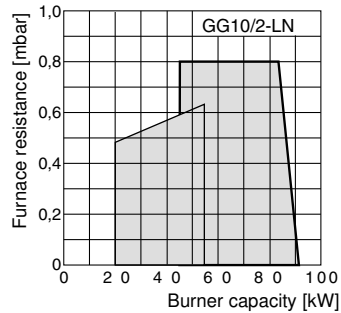
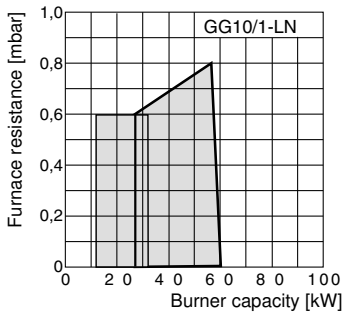

- Mixer unit "close"
- - - Mixer unit "open"

Working ranges acc. to DIN EN 676. The working ranges are referred to 15°C and 1013 mbar.

All information in this technical documentation as well as the drawings, photos and technical descriptions made available by us remain the property of GIERSCH and may not be duplicated without our prior written permission.
Right reserved to effect modifications.

GIERSCH

Giersch GmbH • Brenner und Heizsysteme
Adjutantenkamp 18 • D-58675 Hemer •
Telephone 02372/965-0 • Telefax 02372/61240
Email: info@giersch.de • Internet: <http://www.giersch.de>

