

## Technical Information • Data Sheet

# MG3-ZM-LN

Edition April 2024  
Technical changes in the sense of  
product improvement reserved!

Gas

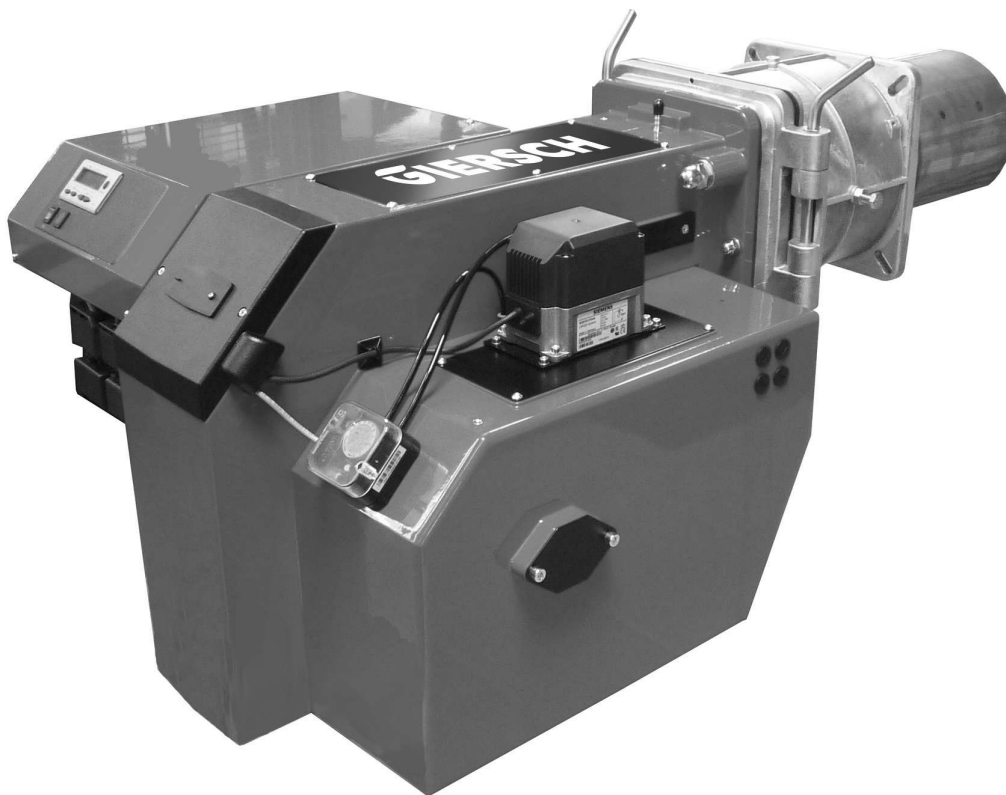

# Electrical connection

## Connection diagram

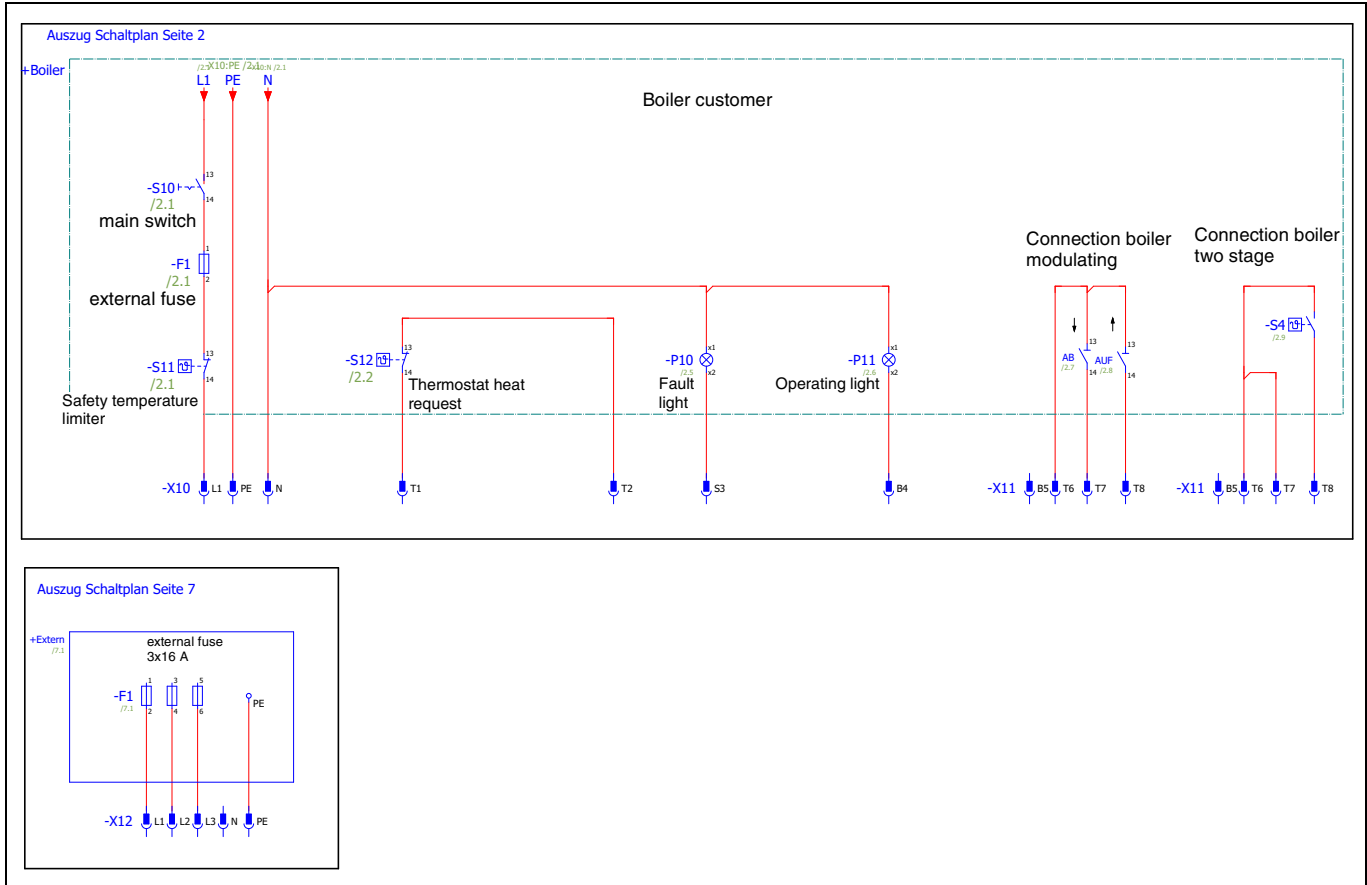

## Gas ramp selection diagrams

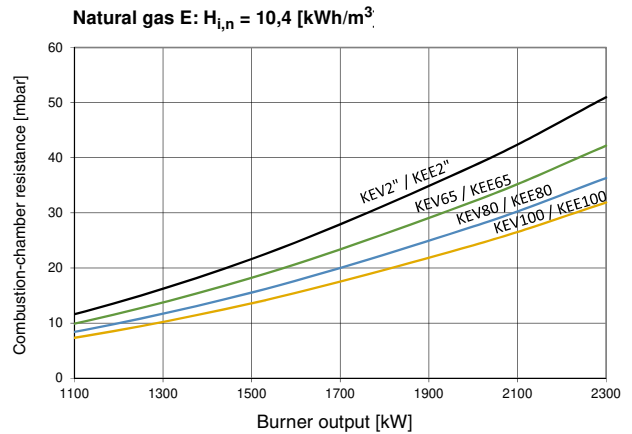
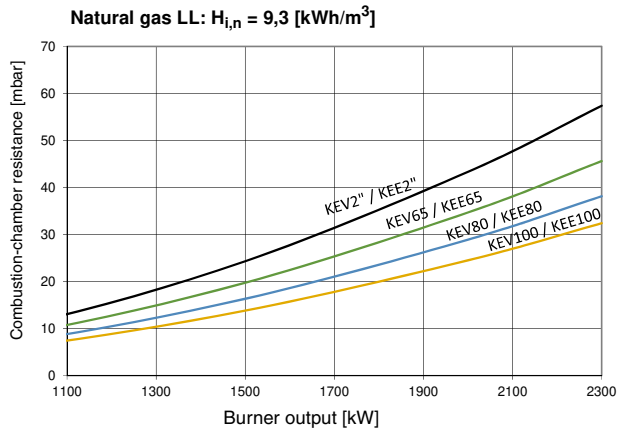

## Technical specifications

	<b>Burner type</b>
<b>Technical specifications</b>	<b>MG3-ZM-LN</b>
Burner output in kW	450 - 2300
Gas type	Natural gas LL + E= „ N“
Mode of operation	two stage / modulating
Mode of operation voltage	230 / 400 V - 50 Hz
Max. power consumption at start / during operation	16,5 A max./ 11,4 A eff.
Electric motor power (at 2800 rpm) in kW	4,5
Flame failure controller	Ionisation
Control box	LMV27
Weight in kg	120
Noise emission in dB (A)	81
Gas burner class	3
NOx Limit value	≤ 80 mg/kWh

## Adjustment tables



The values given in the tables are only setting values for start-up. The necessary system adjustment must be newly determined in the case of deviating data such as boiler output, calorific value and altitude.

**A correction is required in any case.**

During the initial start-up and after each setting, a combustion check must be carried out.

							Natural gas LL: $H_{i,n} = 9,3$ [kWh/m <sup>3</sup> ]				
Burner output <b>MG3-ZM-L-LN</b>		Boiler output $\eta_k = 92\%$		Air flap position		Mixing head position	Gas nozzle pressure		Gas flow rate		
2.Step	1. Step	2.Step	1. Step	2.Step P9	1. Steep P1		2.Step	1. Step	2.Step	1. Step	
[kW]	[kW]	[kW]	[kW]	[°]	[°]	[mm]	[mbar]	[mbar]	[m <sup>3</sup> /h]	[m <sup>3</sup> /h]	
900	450	828	414	16	5,5	20	11,5	3,5	101,3	50,7	
1100	550	1012	506	23	7,5	20	17	4,5	123,9	61,9	
1300	650	1196	598	42	10	20	25,3	6,4	146,4	73,2	
1400	750	1288	690	48	12,5	20	28	8	157,6	84,4	
1600	850	1472	782	55	15	0	33,5	9,7	180,1	95,7	
1800	950	1656	874	63	17,5	0	39	13,2	202,7	107,0	
2100	1050	1932	966	72	20	0	44,5	16,4	236,4	118,2	
2200	1150	2024	1058	80	23	0	50	19,7	247,7	129,5	
2300	1250	2116	1150	90	25,5	0	55,5	23	259,0	140,7	

							Natural gas E: $H_{i,n} = 10,4$ [kWh/m <sup>3</sup> ]				
Burner output <b>MG3-ZM-L-LN</b>		Boiler output $\eta_k = 92\%$		Air flap position		Mixing head position	Gas nozzle pressure		Gas flow rate		
2.Step	1. Step	2.Step	1. Step	2.Step P9	1. Steep P1		2.Step	1. Step	2.Step	1. Step	
[kW]	[kW]	[kW]	[kW]	[°]	[°]	[mm]	[mbar]	[mbar]	[m <sup>3</sup> /h]	[m <sup>3</sup> /h]	
900	450	828	414	16	5,5	20	9,0	2,7	90,6	45,3	
1100	550	1012	506	23	7,5	20	13,3	3,5	110,8	55,4	
1300	650	1196	598	42	10	20	19,8	5,0	130,9	65,4	
1400	750	1288	690	48	12,5	20	21,9	6,3	141,0	75,4	
1600	850	1472	782	55	15	0	26,2	7,6	161,1	85,6	
1800	950	1656	874	63	17,5	0	30,5	10,3	181,2	95,7	
2100	1050	1932	966	72	20	0	24,8	12,8	211,4	105,7	
2200	1150	2024	1058	80	23	0	39,1	15,4	221,5	115,8	
2300	1250	2116	1150	90	25,5	0	43,4	18,0	231,6	125,9	



## Overall dimensions / Boiler connection measures (all dimensions are given in mm)

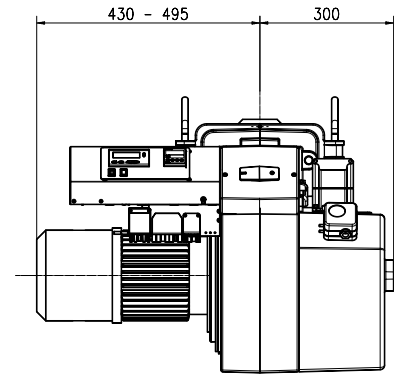
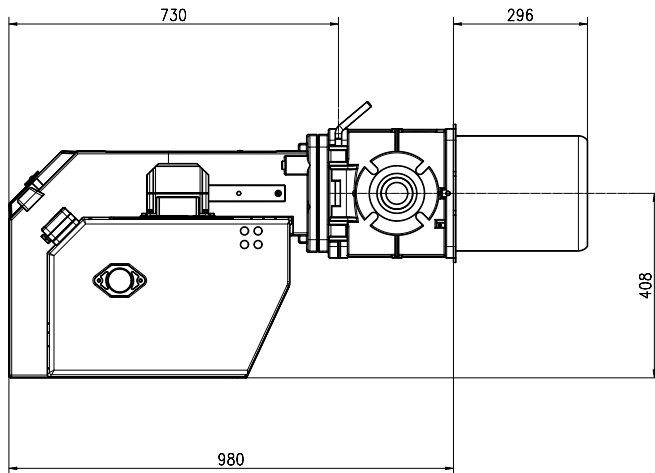

### Boiler connection

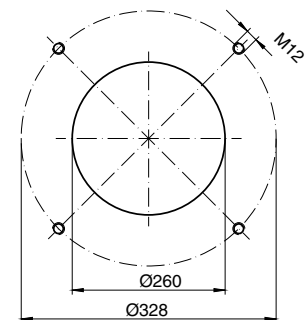

## Working range

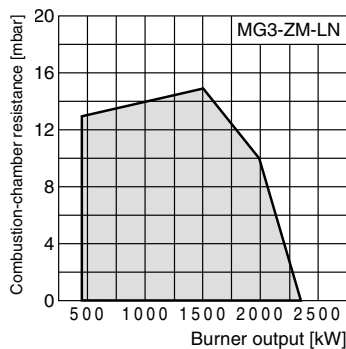

Working ranges according to DIN EN 676. The working ranges refer to 15°C and 1013 bar.

All information in this technical documentation as well as the drawings, photos and technical descriptions placed at your disposal remain our property and may not be duplicated without our written permission given in advance. Right reserved to effect modifications.

# GIERSCH

Giersch GmbH • Brenner und Heizsysteme  
 Adjutantenkamp 18 • D-58675 Hemer • Telefon 02372/965-0 • Telefax 02372/61240  
 E-Mail: info@giersch.de • Internet: <http://www.giersch.de>

