

# HERSCHEL<sup>®</sup>

far infrared heaters

2017/18 product catalogue



## Herschel Far Infrared Heating

Completely changing the way we  
heat ourselves

Efficiency with  
**smart, zoned**  
control

**Energy efficient, sustainable**  
electric heating solution

- **Commercial**
- **Industrial**
- **Domestic**
- **Outdoors**



Select XL 600W

 **HERSCHEL**<sup>®</sup>  
far infrared heaters

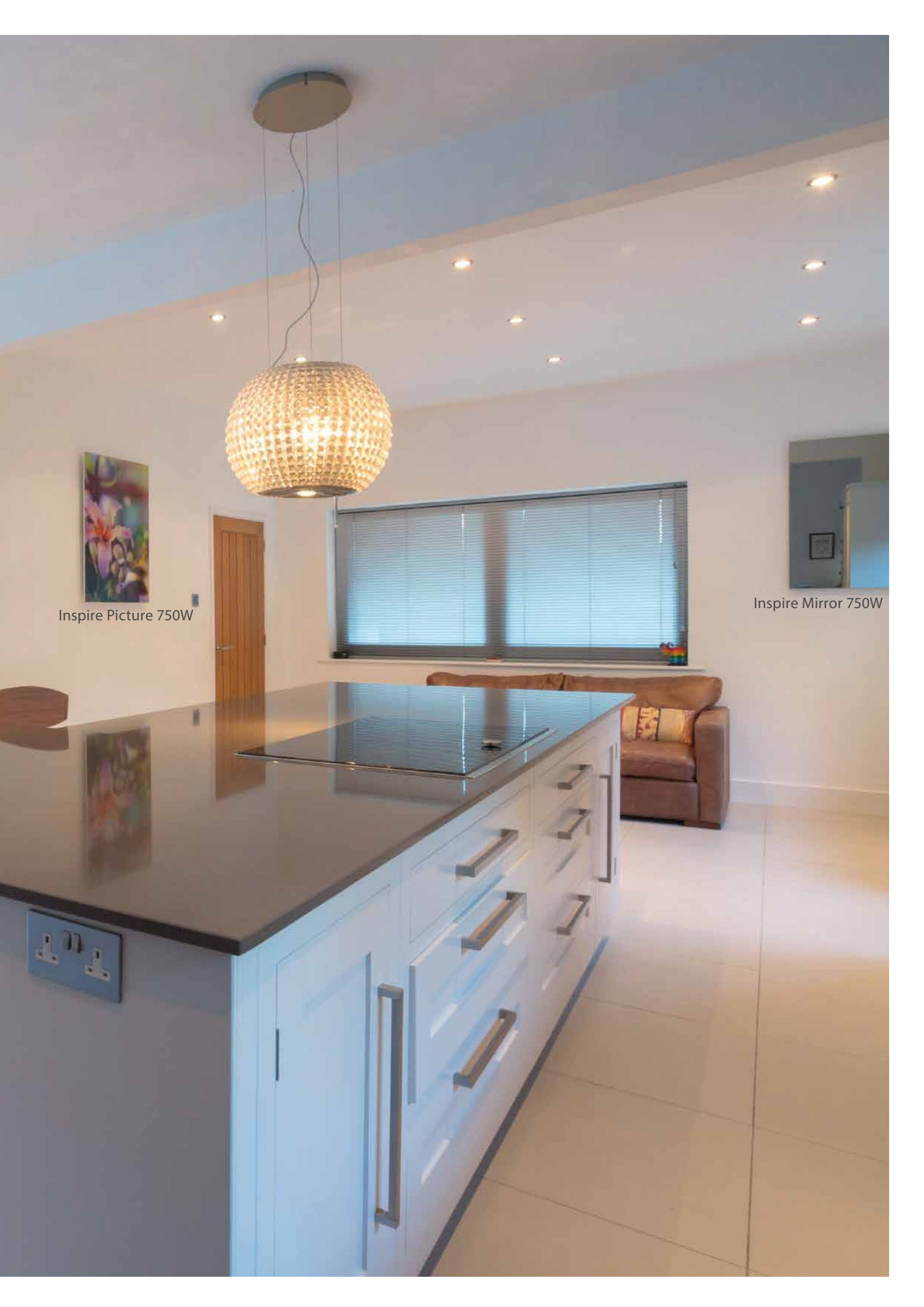

Inspire Picture 750W

Inspire Mirror 750W



Top: Select XL White Glass Towel Rail

Middle: Select White Integrated Ceiling Panels

Bottom: Black Pulsar

# CONTENTS

Intro	<b>5</b>
Applications	<b>6</b>
The future is electric	<b>7</b>
How it works	<b>8</b>
Radiant vs Convection	<b>9</b>
Control – Herschel iQ	<b>10</b>
Comparison of heating technologies	<b>11</b>
Manufacturing, Logistics and Quality	<b>12</b>
Case studies	<b>13</b>
Testimonials	<b>14</b>
6 reasons	<b>15</b>
Sample calculations	<b>16</b>
Product range	<b>17</b>
Space heating range	<b>18</b>
Panel heating range	<b>29</b>
Control system	<b>39</b>



The brightest Far Infrared object in the universe is a galaxy called Messier 82 (Image courtesy of NASA / ESA / STScI)

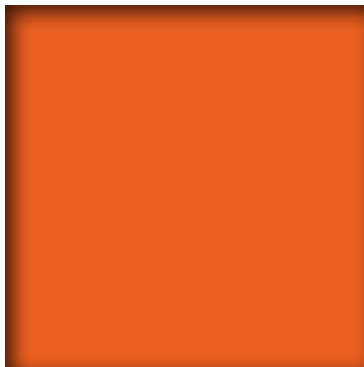

Frederick William Herschel was the first person to discover the existence of Far Infrared heat.



# HERSCHEL IS FAR INFRARED HEATING

Herschel is without doubt the future of heating. Energy efficient, highly controllable, stylish and discreet, comfortable and sustainable heating when you want it, where you want it.

Easy to install, no maintenance and easy to control.

Herschel Far Infrared heaters have zero light and silent operation with no fumes.

Combines with solar to give **FREE heating** and **zero CO<sup>2</sup>**.

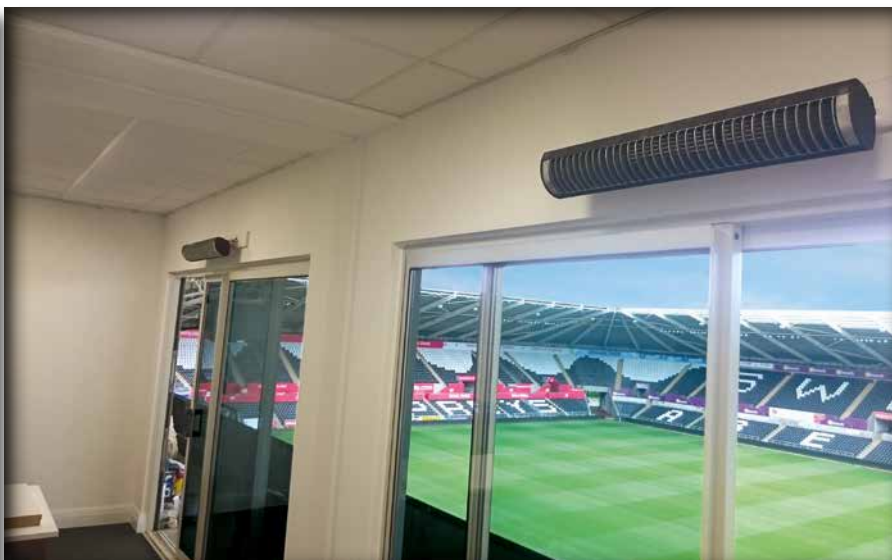

Images show Aspect XL

"They look great and are working very well keeping the reception staff comfortable".

Image shows White Pulsar



## APPLICATION

Our range of Far Infrared heating systems is the most comprehensive in the world. We have heaters to suit any application, from **Domestic** through to **Commercial, Industrial and Outdoor heating**.

Herschel has an unrivalled track record of the widest range of Far Infrared applications.

- Homes
- Office walls and ceilings
- Outdoor patio heaters
- Conservatories
- Shops and salons
- Warehouses and industrial units
- Hotels, restaurants and cafes
- Public spaces
- Garage heating
- Schools
- Churches
- Flood Recovery

“ We apply our **unrivalled expertise** and **knowhow** to give customers the best solutions ”



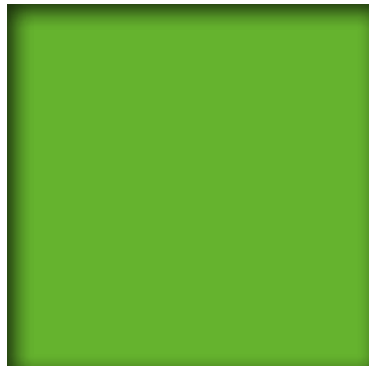
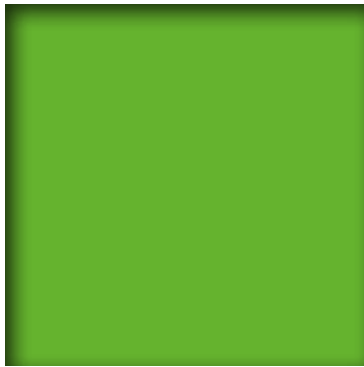

# THE FUTURE IS ELECTRIC

In the future fossil fuels will be a thing of the past and **efficient electric heating** will be the standard way we heat ourselves.

Europe's focus on Energy resulted in the '20-20-20' targets for the EU to achieve by 2020.

- Greenhouse gas emissions 20% (or even 30%, if the conditions are right) lower than 1990
- 20% of energy from renewables
- 20% increase in energy efficiency

## Herschel Far Infrared Heating can be utilised with other Green Energy Technologies

Herschel is a low energy heating solution that, when used with electricity generated by either solar, wind power or other renewable source, is **100% CO<sup>2</sup> free**.

Our panels can be linked to **solar** to provide free heating. As solar battery storage develops the Herschel fit with solar will become increasingly relevant. A typical 4kW Solar PV system combined with Herschel and battery storage could cover the annual heating requirements of the average house in the UK.

Herschel's perfect synergy with **renewable technologies** facilitates the achievement of Corporate Social Responsibility (CSR) policies and meeting targets for reducing carbon emissions.

We have a number of case studies which highlight both the energy savings from installing Herschel heaters as well as the reduction in carbon emissions.



**HERSCHEL** is the **FASTEST GROWING** of the **NEW, ALTERNATIVE HEATING** technologies

“Same feeling of warmth as the winter sun on your face”



## Make your room a 360° radiator

In a cold room the building will 'take' your body heat and make you feel cold. However, if we use Herschel Far Infrared to directly heat the walls, floor and ceiling of a building (the 'thermal mass') the room will stop taking away our body heat, and radiate back the infrared heat, making us feel warm. Once the thermal mass of the building is warm (>17°C), the heater only needs to be on to top up. Convection heaters (electric or gas) mostly heat the air and this does very little to heat the thermal mass of the building. This is why Herschel SAVES ENERGY.

# HOW IT WORKS

## What is Far Infrared heat?

Herschel Far Infrared is low energy electric heating, up to **60% more efficient** than traditional electric heating with the benefits of **increased comfort** levels. It also has many advantages over other alternative heating systems such as air source pumps due to **low costs** of installation, **zero maintenance** and unprecedented ability to **zone and control**.

Far Infrared is radiant heat, it's the same feeling of warmth as the winter sun on your face and the heat from a coal fire. It is even the same form of heat emitted by your own body.

It is the most basic form of heating known to man. Used by cavemen to heat themselves by fires, by Romans in their hypocausts, by log burners and tile stoves. Favoured for millennia because it heats objects, which then radiate back and keep the environment warm around you. Radiant heat does not heat air – which holds little heat and disappears.

But in the last 60 years, we have forgotten about radiant heating: not because a better technology replaced it, but because fossil fuels that powered central heating made it so cheap to heat air.

Today, new technology, in the form of our 100% energy efficient, zero light Herschel Far Infrared heating, is allowing us to use radiant heating once more in a stylish, comfortable and highly controllable way.

Infrared itself breaks into 3 bands, according to temperature: Near, Medium and Far Infrared, the one we're interested in for human '**Comfort**' heating is **Far Infrared** because this is the wavelength we naturally absorb when warm objects radiate heat.

It's the same heat we feel from an environment warmed by the sun, and the wavelength most efficiently absorbed by the body. It is 100% **safe and natural** (it's UV that is harmful, not infrared).





“Radiant heat and convection heat do not compare”



Images show Select XL Glass Black (left) and Select XL Glass White (right)

# RADIANT VS Convection

In terms of heat transfer efficiency, radiant heat (Far Infrared) and convection heat simply do not compare. They have very different heat transfer properties and as far as heating your home, office or workspace goes, it is important to know the difference. Radiant heaters heat objects in the environment which warm up and radiate back. Convection heaters heat air, which retains heat poorly and disappears on draughts. As a result heating air requires much higher energy.

Less intrusive than central heating: less building work and less cost during installation.

## Consider

- Provision of electricity (simply plugs-in)
- Space to hang on a wall or ceiling

## No requirement to consider

- Insulation behind the heat source
- Pipework for water
- Storage of fuel
- Flues / Chimneys
- On-going maintenance

Infrared requires no maintenance and has an incredibly long life so there is no risk of having to revisit the entire installation again in ten years time.

## All other electric radiators are yesterday's technology

Because they heat the air, even the best market leading "low consumption" digital

electric convection radiators need around  $40\text{wm}^3$ . Herschel infrared panels do not heat the air and so typically only need  $25\text{wm}^3$ . Both Herschel and digital electric radiators run for around 40% of the required heating period (often referred to as the "effective power"). That's a massive saving of 37% on electricity consumption by Herschel with even higher savings of up to 60% compared to electric storage heaters.

## Benefits to buildings:

- Reduction of causes of moisture. Far Infrared maintains a higher temperature in the material of a building and a lower temperature in the air so moisture is discouraged
  - **LESS** condensation
  - **LESS** corrosion of metal parts
  - **LESS** salt-damp in stonework
  - **LESS** likelihood of wood rot and bugs
  - **LESS** damage to paint (flaking)
- Far Infrared can be used to heat a zone within a building, something not possible with convection. Herschel heaters can directly heat people in the areas, where they need to be heated
- More constant temperature over periods of operation - fewer hot / cold cycles on the inside (e.g. plasterwork) of the building

**IF BUILDINGS  
COULD DECIDE,  
THEY WOULD  
CHOOSE  
HERSCHEL  
FAR INFRARED**

# CONTROL

“  
Herschel  
is about  
efficiency  
and control”

Make your property **warm and energy efficient with advanced control**

Herschel heaters can just be plugged in, however, to regulate temperature and manage optimum comfort levels and efficiencies simply add Herschel iQ thermostat controls.

Our Herschel iQ controllers provide various flexible solutions, using the latest wireless technology to turn your new Herschel infrared heaters into a cutting edge, smart energy-saving heating system. No-one else offers this winning combination of our stylish and efficient heaters with such a comprehensive and cost effective solution.

For **room by room** control, and brand new for 2017, our Herschel iQ control system is the first to be designed specifically for infrared heating. Our Herschel iQ thermostat, the **T1** is easy to operate and features full 7 day programming with 3 modes for maximum control. The T1 is battery operated and can be easily wall mounted or free-standing. The T1 is RF enabled and wirelessly links to our specially developed R1 receiver. The receiver is then wired to your Herschel heater allowing it to be controlled. The R1 is the smallest, most discreet, and smartest receiver available.

The **R1** receiver can be surface mounted or recessed, features an internal temperature sensor, a one-hour boost function and the latest open window technology. For large rooms, multiple receivers can pair with the T1 thermostat.

Want **Central control**? Our brand new Herschel iQ **WH1** central control unit pairs wirelessly with our R1 receivers and lets you control all your heaters in the property from one unit. The system features full colour touch screen control, 6 zones, full 7 day programming and 3 modes. In addition, the system features one touch on/off for all heaters in the property and comes pre-programmed with our recommended heating schedule to maximise efficiency from the Herschel system. When using the WH1 the R1 reads the temperature, removing the need for separate thermostats in each room.

Want to control with an App? We recommend and sell Lightwave's app-enabled control solution enabling you to control your heating wherever you are and integrate your heating with lighting and security.

Alternatively, Herschel heaters will work with a wide range of other controls including standard room thermostats, wireless thermostats through to comprehensive Building Management Systems.

## Herschel iQ - for every heating application

Herschel iQ WH1 can have up to 6 zones and 6 R1's per zone (36 R1's in total), so can also be used in commercial applications such as offices, guest houses and hotels, care homes and multi-let properties. The system is also appropriate for use in schools, restaurants and pubs, public buildings, warehouses and industrial applications.

Installing Herschel iQ is simple and easy utilising RF technology for wireless communication to the thermostats, keeping hard wiring and installation to a minimum.



Images show T1 Thermostat (top), R1 Receiver (middle), WH1 Whole House Central Control Unit (bottom).

Note the T1 comes with one R1 (additional R1s can be purchased).

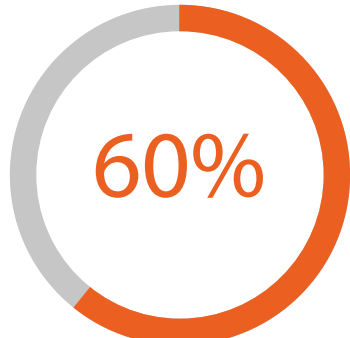

Image shows Inspire Mirror Panel

**“Unbeatable combination of price, efficiency, payback, comfort”**

# COMPARISON OF HEATING TECHNOLOGIES

**PAY BACK**



Delivers up to 60% savings on energy usage over traditional forms of electric heating.

Compared with new technologies such as heat pumps **HERSCHEL FAR INFRARED OFFERS SIGNIFICANTLY QUICKER PAYBACK TIMES** due to the lower costs of installation and lower maintenance.

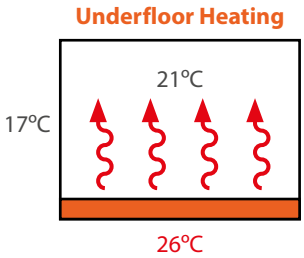

High energy required to disproportionately heat one area, in order to generally warm the air, leaving other materials cold. Once thermostat reaches set point, the floor shuts off and you're left with 17°C "Cold Radiating" walls.

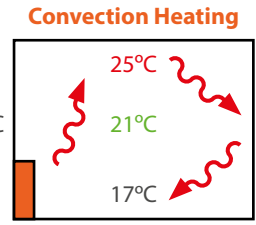

High energy required to disproportionately heat the air higher than you need because it will rise, cool and sink making "ambient" temperature about right and leaving other materials cold.

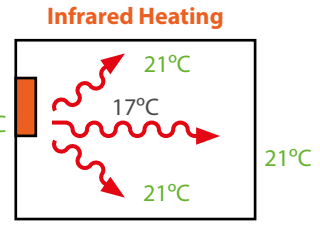

Low energy radiates heat slowly to all areas of room which all warm up over time and start "radiating back". Air remains relatively cool.

Typical 3 Bed House - Total annual cost of ownership comparison

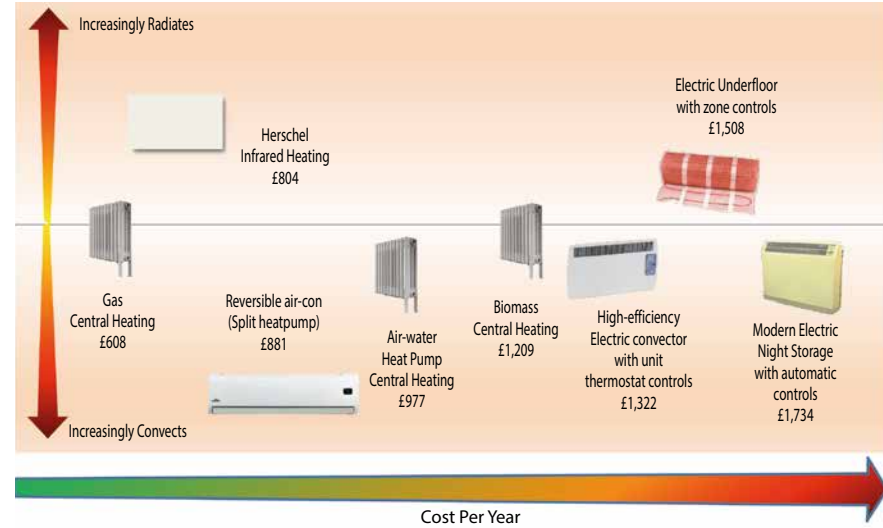

### How Herschel Infrared Compares

**vs Heatpumps**

- much cheaper purchase price
- lower installation costs
- no ongoing maintenance
- no noisy fan
- no plumbing/leaks

**vs Night storage heaters**

- far more economical
- much better control
- does not require Economy 7
- much nicer looking

**vs Biomass**

- no central boiler - noise, space
- significantly cheaper purchase price
- no maintenance
- no ordering, delivery and storage of pellets / fuel
- no plumbing / leaks

Total cost of ownership includes: ▪ purchase cost ▪ installation cost ▪ annual running cost ▪ maintenance cost ▪ replacement cost  
All figures taken from manufacturer websites and UK Energy Savings Trust calculations for a 3 bedroom house. RHI and other grants not included.

“Unique with our in house team of chartered surveyors”

# MANUFACTURING LOGISTICS QUALITY

## Pioneering Development

Herschel constantly strives to develop highly innovative products listening to market requirements and spotting new applications in need of an improved heating solution.

Two examples include the Select XL, where we have brought a high quality frameless panel into the mass market, and the Aspect XL where we have brought the benefits of our commercial range into the high end consumer market.

## Quality components

We ensure the highest quality materials and components are employed with strict processes in place to ensure quality compliance. Quality is fundamental and intrinsic to Herschel and the way in which the organisation is managed.

Our heaters are certified to appropriate country standards, as a bare minimum, as well as rigorous testing by TÜV or equivalent bodies.

## Quality Assurance

We guarantee our heaters for up to 10 years\*. Made of the highest quality components, our heaters are built to last. Unlike other forms of heating we utilise solid state emitters and minimise the use of integrated control components. This maximises the lifetime of the heaters.

Herschel panel ranges (Inspire, Select and Select XL) are fully certified by the leading German Testing laboratory (TÜV) to GS Standards and are RoHS and REACH Compliant.

**SURVEY SERVICE**



**QUALITY ASSURED**



**ACCREDITED TRAINING**



## Logistics

We carry the UK's largest stocks of infrared heaters and offer next day delivery on 90% of our product lines.

## Survey Service

Our Commercial and Technical department is headed up by our team of Chartered Surveyors who have the most experience in the application of Far Infrared in the UK. We offer a desktop review service, within a 7 day turnaround, and site visits can be arranged for complex or specialist projects.

## Training and Accreditation

The Herschel Infrared Technology Centre provides access to free online training on everything you need to know on Far Infrared, from basic introductory installer courses to advanced accreditation.

[www.herschel-infrared-technology-center.com](http://www.herschel-infrared-technology-center.com)

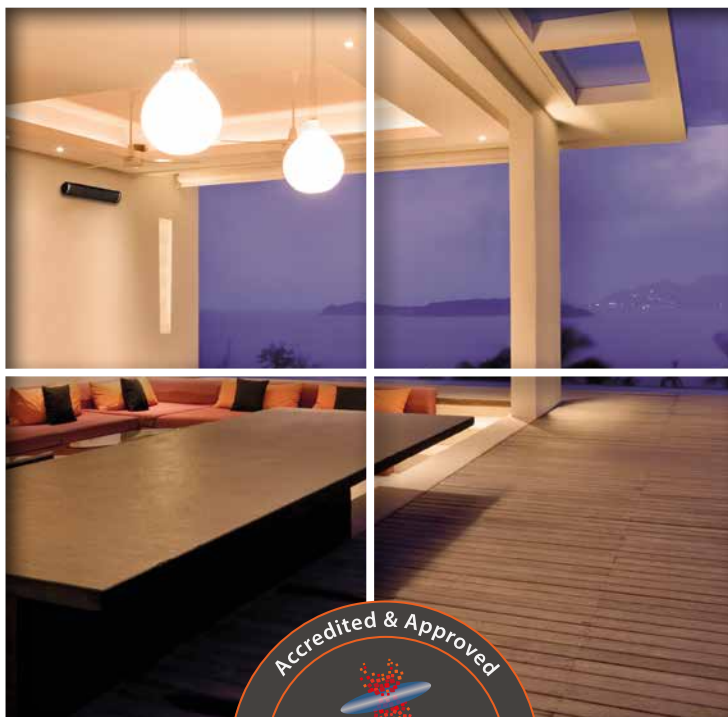

Image show Aspect XL



\* Requires online registration

# CASE STUDIES

“Market leader”

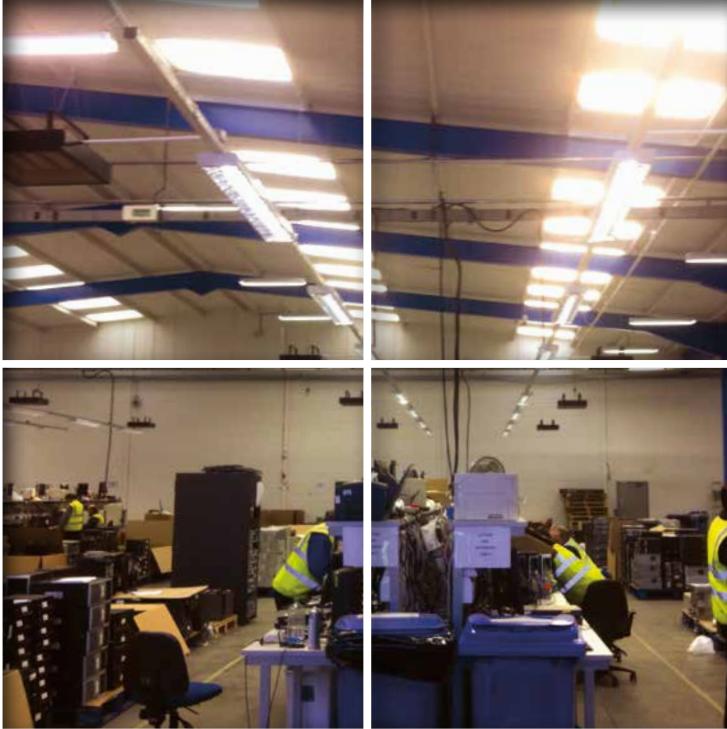

**A leading FM company instructed Herschel to look at a heating solution to reduce consumption within a vehicle testing and storage warehouse.**

## Issues:

- Existing gas fired heating system was not zoned
- Large amounts of air heated for significant time still unable to achieve a comfortable temperature
- Lack of heating controls and inefficient heating system meant significant costs

## Herschel Solution:

- Combined Infrared electric heaters with pre-programmable push button timers
- Enabled heating to be zoned effectively in the areas required
- Controls mean heaters only used for time required

## Estimated Annual Savings

- 90% reduction in energy consumption (kW/hrs)
- 71% saving off current energy bills
- 76% reduction in CO<sup>2</sup> and Carbon Emissions (kg)
- C.3.6 yr estimated payback period

## Independent Field Trial at a leading UK national hotel chain

Herschel was approached to find an infrared solution to reduce heating costs and provide more effective heating for hotel rooms.

## Key findings for February 1st to April 30th 2016

- ✓ Existing convector heaters consumed **c.21.5%** more energy on average than Herschel Select XL
- ✓ Higher savings for Herschel on colder days <5C and in rooms with more external walls (28%)
- ✓ Average 0.8kw per room per day saving = 190kwh per room per annum = £26 per room per annum saving\*
- ✓ Estimated annual saving would be **£1.2m** per annum across entire estate\*\*
- ✓ Would also free up wall space

## Positive customer feedback

- "more comfortable than convector heaters"
- "no noise"
- "heats very quickly"
- "more stable with less need to adjust thermostat"

\*Based on 34 weeks heating season (per Energy Saving Trust).

\*\*Hotel chain has 44,000 UK rooms with electric convection heating

Take a look at our website, [www.herschel-infrared.com](http://www.herschel-infrared.com), for more details on other Herschel case studies within the commercial, industrial, domestic and outdoor markets.



Image shows Inspire White

# TESTIMONIALS

**Charlie Luxton, Television Presenter & Architectural Designer**

"I wanted an efficient, cost effective and easy to install electric heating solution to complement a solar PV installation for my recent eco self-build in Cornwall and the Herschel infrared panels fitted the brief perfectly".

"We are halfway through our first winter and the panels are exceeding expectation, the house is warm and comfortable without knowing where or how it is being heated. The internet control and monitoring is fantastic, allowing us to pre-heat the house before anyone arrives and we can check the temperatures of rooms when no one is there, giving us peace of mind".

**Inspire Panels/Towel rail heater: Charlie Luxton, December 2016**

"They have proved great for our staff morale, are very safe and overcome the challenges on our site around airflow and stratification. A very elegant solution. Thanks for such a great product and the advice around the installation".

**Pulsar: City of Westminster College, December 2016**

"The heaters are now up and running and working as we had hoped. All the church members seem to be very impressed".

**Advantage IR3's: Bekesbourne Church, April 2016**

"The heaters are stylish, easy to use and fit in perfectly with our period property. Guests just cant believe our mirrors are our heating!"

**Mirror and White Panels: Period property, Rebecca and Richard Collis, February 2016**

"We are delighted! The process of installation was extremely easy and efficient. The panels are so unobtrusive that visitors are surprised when they are pointed out, the Building Control inspector had not seen these units before and remarked on their efficiency - the electrician has said that he will be installing one or more in his home!"

**White Panels: Domestic: Hugh Richards, January 2016**

"The heaters in the barn are absolutely fantastic. I cannot tell you how pleased we are with them. They are working better than we could ever imagine".

**Space Heating: Blake Hall, Wedding Venue and Barn, June 2014**

“Electrician was so impressed he might even buy some himself”

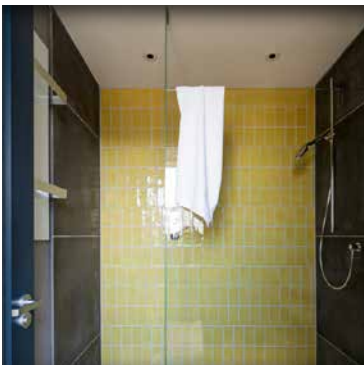

Image shows Select XL White Glass Towel Rail

# CHOOSE HERSCHEL

## - SIX REASONS WHY

FAR INFRARED HEATING IS 100% NATURAL

1

The human body is designed to accept and to emit infrared waves.

HEATS THE FABRIC OF THE BUILDING, NOT AIR

2

The fabric of the building can retain heat for longer, creating better thermal comfort, so your property will be warmer and cosier.

LESS DAMP AND MOULD

3

Herschel Far Infrared heating warms walls and keeps them dry.

GREATLY REDUCED ENERGY USE

4

Compared with other gas, oil or electric solutions, Herschel infrared heating can save up to 60% of the annual energy usage.

NO MAINTENANCE OR SERVICING

5

Solid state elements unlike water-based heating or fan-assisted systems, which often require servicing, inspection and repair costs.

CO2 FREE

6

Combined with electricity from wind or solar, it is one of the only heating systems that can truly claim to be **100% carbon free.**



Image shows Inspire White Glass

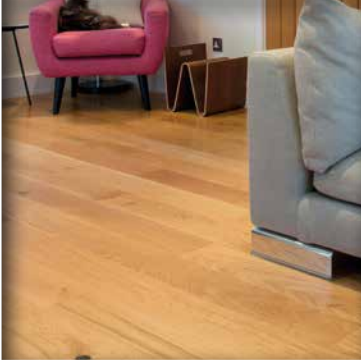

“Heats the fabric of the building, not air”

# SAMPLE CALCULATIONS

## Room Heating

The power (wattage) of the heater needed **averages 25wm<sup>3</sup>** but will depend upon the construction type and INSULATION levels. Better insulated rooms will need less power. The aim of Infrared is to heat the “thermal mass” of the room. This can mean 2-3 days of the heaters being fully on at the start of the winter season. After that the thermal mass just needs “topping up”. We estimate an average of 5 hours running time every day over the heating season. **This compares to an average of 40-45wm<sup>3</sup> for convection heating.**

Watts per mtr cubed	Insulation levels	
7wm <sup>3</sup>	Passive house	Completely airtight modern
20wm <sup>3</sup>	New Build	Standard new build
25wm <sup>3</sup>	Modern building	1950's onwards
30wm <sup>3</sup>	Old building	Pre-1950's non cavity wall

## Space Heating – Large areas and outdoors

It is very expensive to heat very large areas such as warehouses, churches, halls. With convection heating it is not possible to create zones within a large building or large area (the air can't be contained), so the whole building / large area needs to be heated. The benefit of radiant heating is that we can directly heat people in the areas where they need to be heated, so heaters can be mounted only in those areas (we call them zones).

Heater	Zone Indoors	Zone Outdoors
IR2 / XL2 1300w	6-9m <sup>2</sup>	3-6m <sup>2</sup>
IR3 / XL3 1950w	9-12m <sup>2</sup>	4.5-9m <sup>2</sup>
IRP4 2600w	12-21m <sup>2</sup>	N/a
Pulsar 1800w	8-15m <sup>2</sup>	N/a
Pulsar 2400w	12-20m <sup>2</sup>	N/a

Within the lower range of the heated ZONE you will feel the heat and your body will absorb the heat whilst the heater is on. Within the entire zone, the far infrared will be absorbed by the building and if there are sufficient heaters in the area to build up THERMAL MASS then the ambient temperatures will increase. Note however, that this depends upon the construction of the building, the number of heaters within the area, the insulation levels and running times. This is a technical area which will need involvement of the Commercial and Technical Division. Our Commercial and Technical Division offer a survey service to assist here.



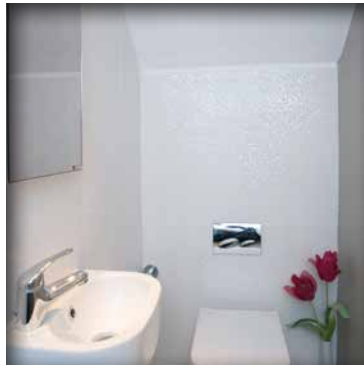

“Commercial,  
domestic,  
industrial,  
outdoors”

Images show: Picture Panel, Mirror Panel, Black Pulsar, Aspect XL.

**ZERO LIGHT  
COMFORT  
HEATING  
SOLUTION  
FOR ANY  
APPLICATION**

## PRODUCT RANGE

### Indoor Space Heaters

Public spaces – Our Pulsar and Aspect ranges are the most stylish infrared heaters on the market, perfect for public spaces where aesthetics are important such as restaurants, churches or public halls.

Industrial and Commercial buildings – Our Advantage range is designed for large industrial spaces such as warehouses, depots and garages where effective zoned heating is required.

### Outdoor Space Heaters

The Aspect range is the most attractive and best performing far infrared heater on the market.

### Panels

Our panel heaters are ultra slimline, with large surface areas, specially designed for heating rooms. They can be ceiling or wall-mounted and a number of designs are available including standard white, glass, mirrors, and even bespoke pictures.

The **Select XL** is our performance range featuring our specially-developed Herschel COSIX Cell technology heating element and unique EASYFIX mounting system.

**Select** is our standard range, offering all the benefits of Far Infrared at great value.

**Inspire** is our premium range, made in Germany, available in the widest range of finishes and complete with a 10 year warranty.

	Select	Select XL	Inspire
Wall and ceiling	✓	✓	✓
White finish	✓	✓	✓
Insulated		✓	✓
Frameless		✓	✓
Aluminium construction		✓	✓
Easyfix mounting	✓	✓	
Glass		✓	✓
Mirror		✓	✓
Picture			✓
10 year warranty**	*	*	✓

\*Select and Select XL both come with 5 year warranty

\*\* Requires online registration

All our panel ranges are fully tested by TÜV to GS, CE and international electrical Safety Standards.

# SPACE HEATING RANGE

Zero light heaters  
for large areas and  
zoned heating





TABLE 1	1.3 kW System	
Rated Voltage (V)	120	230
Rated Current (A)	10.8	5.7
Fuse/Circuit Breaker Rating (A)	16	10

TABLE 2	Indoors	Outdoors
Heated Zone	6-9m <sup>2</sup>	3-6m <sup>2</sup>

*This area heated figure is based on a mounting height of 2.3 - 2.5m*

RATED POWER	PART NO.	ELEMENTS	FRAME
1.3 kW (2 x 650 W)	IRXL2-1300B	Two black glazed ceramic elements	Black powder coated extruded aluminium

## INSTALLATION AND OPERATING INSTRUCTIONS

The low operating cost, large heat area and high reliability of the Herschel Aspect XL2 is why the world's hotels, restaurants and public places are turning to the Herschel Aspect as the system of choice for reliable, cost effective and fail safe comfort both indoors and outdoors. It is now increasingly being used by discerning domestic customers to heat their patios, conservatories and terraces too.

The Herschel Aspect XL2 consists of 2 highly emissive ceramic heating elements mounted in a directional, reflective grill-protected unit. It is designed to gently warm people both indoors and in an outdoor covered area using infrared heat.

Infrared heat is a 100% natural radiating heat that humans readily absorb, producing a feeling of great comfort and well-being. Infrared heat produced from the Herschel Aspect warms you directly without heating the air in between: meaning the heat goes where you want it to. No wonder customers immediately warm to Herschel Aspect. The system is easy to install; extremely discreet, produces no red glow and requires next to no maintenance.

The heater will directly warm people within the lower range of the Heated Zone (note: air movement may reduce area coverage). Within enclosed areas the thermal mass of the building will also be heated within the entire zone. Dependent upon the property age/type, insulation levels, number of heaters used and running times this will increase the ambient temperatures. For larger commercial projects or where different mounting heights are required we would always recommend Herschel carry out a survey or detailed desktop assessment.

## DIAGRAM 1

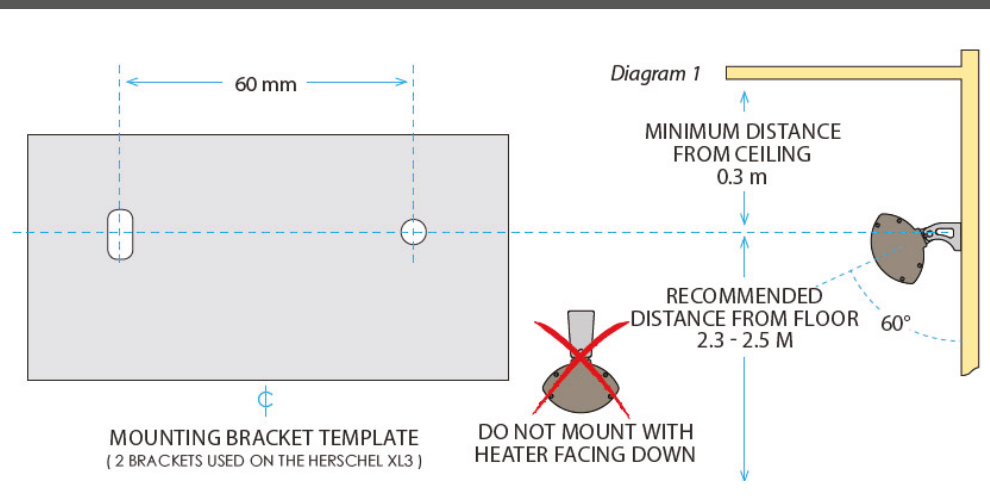

## IMPORTANT

In areas with air movement/wind the directional Far Infrared spread may reduce by 1/3 to 1/2. In these areas we recommend mounting at the lowest height and proportionally increasing the number of heaters.

The Herschel Aspect XL2 rises to very high temperatures in use and the unit (in particular the heater elements) must not be touched when power is applied.

Do not touch the unit when it is on. After switch off the elements remain hot for a considerable time and the unit should not be touched for a minimum of 30 minutes.

NEVER use the heater to ignite materials. Ensure supply voltage does not exceed 245 volts.

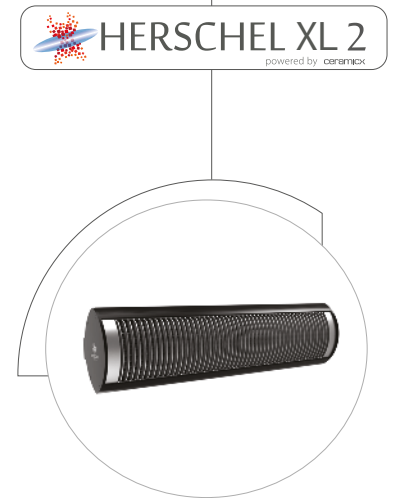

- 2 Ceramicx CHE Ceramic Elements
- Heater Size 550 x 95 x 138 mm - 3.4kg
- Aluminised steel reflectors
- Heating Up Time < 5 Minutes
- Useful Wavelength Range 2 - 10 µm
- IP rating: IPX4

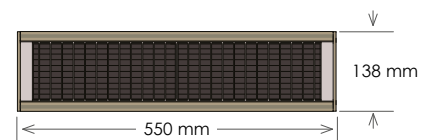



TABLE 1	1.95 kW System		TABLE 2	Indoors	Outdoors
Rated Voltage (V)	120	230	Heated Zone	9-12m <sup>2</sup>	4.5-9m <sup>2</sup>
Rated Current (A)	16.25	8.5	<i>This area heated figure is based on a mounting height of 2.3 - 2.5m</i>		
Fuse/Circuit Breaker Rating (A)	25	16			

RATED POWER	PART NO.	ELEMENTS	FRAME
1.95 kW (3 x 650 W)	IRXL3-1950B	Three black glazed ceramic elements	Black powder coated extruded aluminium

## INSTALLATION AND OPERATING INSTRUCTIONS

The low operating cost, large heat area and high reliability of the Herschel Aspect XL3 is why the world's hotels, restaurants and public places are turning to the Herschel Aspect as the system of choice for reliable, cost effective and fail safe comfort both indoors and outdoors. It is now increasingly being used by discerning domestic customers to heat their patios, conservatories and terraces too.

The zero light Herschel Aspect XL3 consists of 3 highly emissive ceramic heating elements mounted in a directional, reflective grill-protected unit. It is designed to gently warm people both indoors and in an outdoor covered area using infrared heat.

Infrared heat is a 100% natural radiating heat that humans readily absorb, producing a feeling of great comfort and well-being. Infrared heat produced from the Herschel Aspect warms you directly without heating the air in between: meaning the heat goes where you want it to. No wonder customers immediately warm to Herschel Aspect. The system is easy to install; extremely discreet, produces no red glow and requires next to no maintenance.

The heater will directly warm people within the lower range of the Heated Zone (note: air movement may reduce area coverage). Within enclosed areas the thermal mass of the building will also be heated within the entire zone. Dependent upon the property age/type, insulation levels, number of heaters used and running times this will increase the ambient temperatures. For larger commercial projects or where different mounting heights are required we would always recommend Herschel carry out a survey or detailed desktop assessment.

- 3 Ceramicx CHE Ceramic Elements
- Heater Size 800 x 95 x 138 mm - 4.4kg
- Aluminised steel reflectors
- Heating Up Time < 5 Minutes
- Useful Wavelength Range 2-10 µm
- IP rating: IPx 4

## DIAGRAM 1

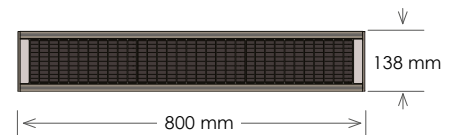
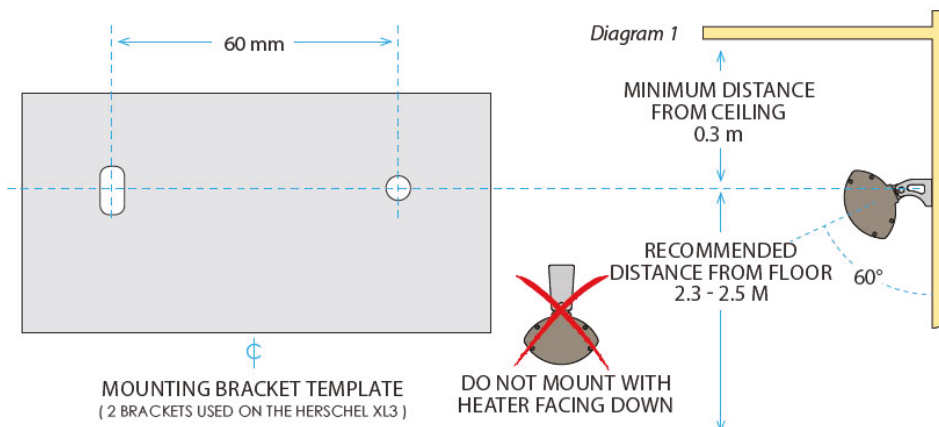

## IMPORTANT

In areas with air movement/wind the directional Far Infrared spread may reduce by 1/3 to 1/2. In these areas we recommend mounting at the lowest height and proportionally increasing the number of heaters.

The Herschel Aspect XL3 rises to very high temperatures in use and the unit (in particular the heater elements) must not be touched when power is applied.

Do not touch the unit when it is on. After switch off the elements remain hot for a considerable time and the unit should not be touched for a minimum of 30 minutes.

NEVER use the heater to ignite materials.

Ensure supply voltage does not exceed 245 volts.





## IMPORTANT INFORMATION

Please read the following information fully, as safe and reliable operation depends on correct installation. Please keep this instruction sheet for future reference.

The AC mains supply is dangerous and potentially lethal. Ensure the mains supply is switched off at the consumer unit (fuse box) before attempting any work on electrical circuits. Wiring to this unit must be connected in accordance with the relevant national electrical safety standards. This unit must only be installed by a competent and qualified electrician. This appliance must be earthed.

## ELECTRICAL INFORMATION

The electrical supply to the unit should be provided by connecting to a circuit, which is protected by a fuse or miniature circuit breaker suitable for the electrical rating of the unit and in accordance with Table 1.

The supply to the Herschel Aspect XL must be separately switched. Alternatively a switched fused spur taken from a ring main can be used. The spur fuse should also be rated in accordance with the appropriate table. In either case the switch used to operate the Herschel Aspect XL must be indoors and readily accessible.

The cable used to connect to the existing wiring should be correctly rated solid core wiring cable. Please note that the use of flexible appliance cable with stranded conductors for permanent wiring (except for the final connection between a cable outlet and the fixed equipment) is prohibited by IEE wiring regulations. Where applicable, these regulations preclude the use of a 13A plug and socket for powering the Herschel Aspect XL.

For the final connection to the Herschel Aspect XL, only the flexible cable and cable entry supplied with the unit must be used. The cable must connect to the supply in a suitable enclosure or cable outlet designed for that purpose. The cable outlet current carrying capacity must be greater than the recommended fuse current rating given in Table 1.

If the cable outlet is outdoors it must be of waterproof construction. If the flexible cable is taken through an outside wall for connection purposes, suitable conduit or mechanical protection must be used through the wall to protect the cable from mechanical damage within the wall. The mounting position of the unit must ensure that any mechanical damage to the flexible cable is unlikely. If physical damage to the cable is possible, suitable conduit protection must be provided.

## MOUNTING POSITION ( see Diagram 1 )

The Herschel Aspect XL must be located in a position to allow proper and efficient use but one that ensures hot parts are not touched accidentally. The recommended installation height of the Aspect XL is 2.3m to 2.5m (90"-98") from the floor and under no circumstances is it to be installed at less than 1.8m from the floor. In all cases it should be installed at a height where it cannot be touched in operation. Consideration should be given to any temporary or occasional additions such as stages or platforms, and the height should be adjusted accordingly.

The Herschel Aspect XL should be firmly and permanently attached to the wall using the bracket supplied, with the heaters angled down at 60 degrees from vertical. The Herschel XL must not be attached so as to face or be close to any combustible material (eg, wood or PVC cladding, fascia or soffit)

## EXTERIOR USE

The unit is protected against water ingress (protection level IPX4), however it is recommended that the unit is installed in a covered outdoor area to give maximum protection and longevity against the effects of driving rain, wind, frost, salt and water contaminations, etc.

The canopy/roof/cover must be of a permanent nature, there must be a minimum clearance of 0.3m (12") between the cover and any part of the Herschel Aspect XL and the cover must extend a minimum of 2m (79") from the wall.

## WARRANTY

The Herschel Aspect XL is guaranteed against failure due to faulty materials or workmanship for five years from date of purchase. In the unlikely event of failure of the unit within this time, the unit must be returned to the supplier for repair or replacement. The Herschel Aspect XL contains no customer-maintainable parts.

The guarantee is invalid if the correct instructions have not been adhered to.

## MAINTENANCE

The Herschel Aspect XL is maintenance free but to maintain appearance it should occasionally be cleaned all over with a soft dry cloth. No abrasive cloths or cleaners should be used and appliances such as pressure washers, steam cleaners etc, should never be used.

Cleaning should only be done when the unit is cold and switched off. All personnel cleaning and maintaining the unit must have suitable training and information to carry out the operation safely.

## IMPORTANT NOTICE TO PURCHASER

Before utilizing the product, the user should determine the suitability of the product for its intended use. HERSCHEL INFRARED LTD expressly disclaims the implied warranties and conditions of merchantability and fitness or a particular purpose. In no case shall HERSCHEL INFRARED LTD be liable under any legal theory, including but not limited to contract or strict liability, for any direct, indirect special, incidental or consequential damages resulting from product use.

Check that the mains supply is switched off, and then provide the mains supply connection to the Herschel Aspect XL3 using the specifications supplied earlier.

The BROWN wire is to be connected to LIVE ('L'), the BLUE wire to NEUTRAL ('N') and the GREEN/YELLOW wire to EARTH ('E'). Any exposed flexible cable is to hang DOWN (not tied up) and must have adequate clearance from the heater to prevent scorching or damaging the cable.

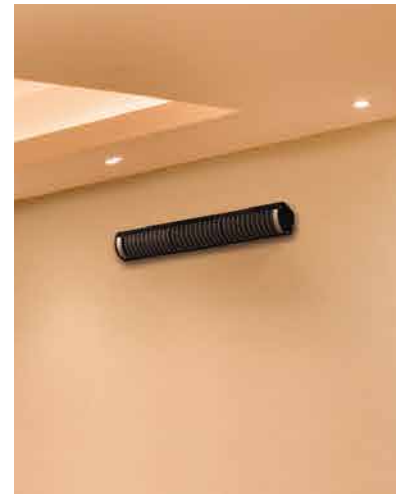



TABLE 1	1.3 kW		1.95 kW		TABLE 2	1.3 kW	1.95 kW
Rated Voltage (V)	115	230	115	230	Heated Zone	6-9m <sup>2</sup>	9-12m <sup>2</sup>
Rated Current (A)	11.3	5.7	17.0	8.5	<i>This area heated figure is based on use indoors and a mounting height of 2.3 - 2.5m</i>		
Fuse/Circuit Breaker Rating (A)	16	10	25	16			

RATED POWER	PART NO.	ELEMENTS	FRAME
1.3 kW (2 x 650 W)	IR2-1300W	Two white glazed ceramic elements	Stainless steel body
1.3 kW (2 x 650 W)	IR2-1300B	Two black glazed ceramic elements	Black powder coated stainless steel body
1.95 kW (3 x 650 W)	IR3-1950W	Three white glazed ceramic elements	Stainless steel body
1.95 kW (3 x 650 W)	IR3-1950B	Three black glazed ceramic elements	Black powder coated stainless steel body

## INSTALLATION AND OPERATING INSTRUCTIONS

Heating large indoor spaces is both a necessity and a challenge - and in certain circumstances a legal requirement. The low operating costs, large heat area and high reliability of the Herschel Advantage IR2 and Herschel Advantage IR3, are why industrial units, workshops and public spaces are turning to the Herschel Advantage IR range as the system of choice for reliable, cost-effective and failsafe indoor heating.

The Herschel Advantage IR consists of 2/3 highly emissive ceramic heating elements mounted in a directional, reflective grill-protected unit. It is designed to gently warm people in large indoor spaces using infrared heat.

Infrared heat is a 100% natural radiating heat that humans readily absorb, producing a feeling of great comfort and well-being. Infrared heat produced from the Herschel Advantage IR warms you directly without heating the air in between: meaning the heat goes where you want it to and doesn't just convect upwards to heat the ceiling. No wonder customers immediately warm to Herschel Advantage IR.

The system is easy to install; extremely discreet, produces no red glow and requires next to no maintenance. The heater will directly warm people within the lower range of the Heated Zone (note: air movement may reduce area coverage). Within enclosed areas the thermal mass of the building will also be heated within the entire zone. Dependent upon the property age/type, insulation levels, number of heaters used and running times this will increase the ambient temperatures. For larger commercial projects or where different mounting heights are required we would always recommend Herschel carry out a survey or detailed desktop assessment.

## DIAGRAM 1

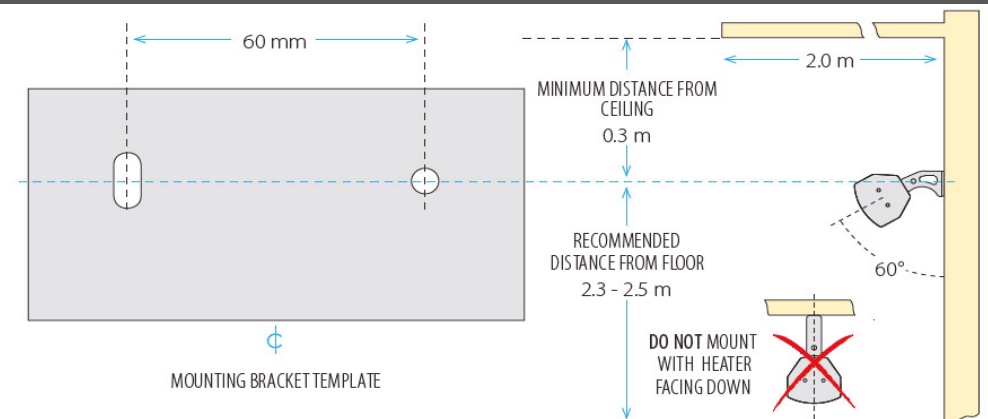

## IMPORTANT

The heating elements reach very high temperatures without visible signs of the unit being on. Because Advantage IR2 & IR3 are not fitted with a protective grill, the heaters are not for domestic or household use. Also, the heaters must not be used or installed in any commercial premises where they can be accidentally touched or where there is a risk of damage to the ceramics elements.

In areas with air movement/wind the directional Far Infrared spread may reduce by 1/3 to 1/2. In these areas we recommend mounting at the lowest height and proportionally increasing the number of heaters.

The Herschel Advantage IR rises to very high temperatures in use and the unit (in particular the heater elements) must not be touched when power is applied.

Do not touch the unit when it is on. After switch off the elements remain hot for a considerable time and the unit should not be touched for a minimum of 30 minutes. NEVER use the heater to ignite materials. Ensure supply voltage does not exceed 245 volts.

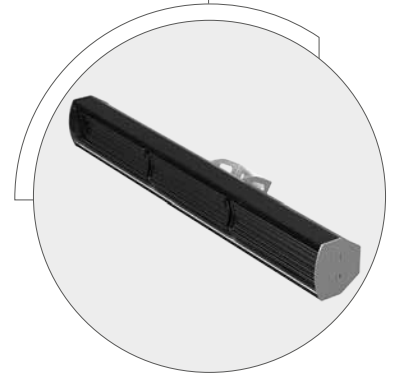
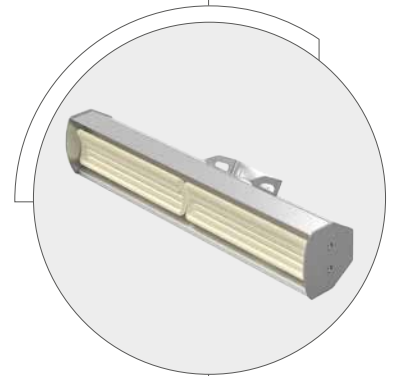

- 2/3 Ceramixx FTE Ceramic Elements
- IR2 Heater Size 509 x 100 x 166mm - 3.4kg
- IR3 Heater Size 760 x 100 x 166mm - 4.4kg
- Aluminised steel reflectors
- Heating Up Time < 5 Minutes
- Useful Wavelength Range 2 - 10 µm
- IP rating: IPX4

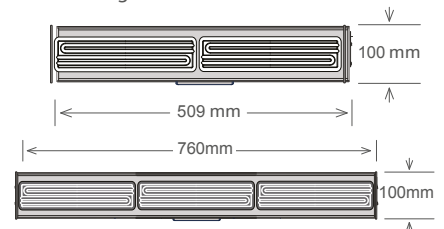

RÖHS COMPLIANT CE For Commercial Use Only  
Installed ceramic heaters are UL recognised (file no. E214574)



## IMPORTANT INFORMATION

Please read the following information fully, as safe and reliable operation depends on correct installation. Please keep this instruction sheet for future reference.

The AC mains supply is dangerous and potentially lethal. Ensure the mains supply is switched off at the consumer unit (fuse box) before attempting any work on electrical circuits. Wiring to this unit must be connected in accordance with the relevant national electrical safety standards. This unit must only be installed by a competent and qualified electrician. This appliance must be earthed.

## ELECTRICAL INFORMATION

The electrical supply to the unit should be provided by connecting to a circuit, which is protected by a fuse or miniature circuit breaker suitable for the electrical rating of the unit and in accordance with Table 1.

The supply to the Herschel Advantage IR must be separately switched. Alternatively a switched fused spur taken from a ring main can be used. The spur fuse should also be rated in accordance with the appropriate table. In either case the switch used to operate the Herschel Advantage IR must be indoors and readily accessible.

The cable used to connect to the existing wiring should be correctly rated solid core wiring cable. Please note that the use of flexible appliance cable with stranded conductors for permanent wiring (except for the final connection between a cable outlet and the fixed equipment) is prohibited by IEE wiring regulations. Where applicable, these regulations preclude the use of a 13A plug and socket for powering the Herschel Advantage IR.

For the final connection to the Herschel Advantage IR, only the flexible cable and cable entry supplied with the unit must be used. The cable must connect to the supply in a suitable enclosure or cable outlet designed for that purpose. The cable outlet current carrying capacity must be greater than the recommended fuse current rating given in Table 1.

If the cable outlet is outdoors it must be of waterproof construction. If the flexible cable is taken through an outside wall for connection purposes, suitable conduit or mechanical protection must be used through the wall to protect the cable from mechanical damage within the wall. The mounting position of the unit must ensure that any mechanical damage to the flexible cable is unlikely. If physical damage to the cable is possible, suitable conduit protection must be provided.

## MOUNTING POSITION ( see Diagram 1 )

The Herschel Advantage IR must be located in a position to allow proper and efficient use but one that ensures hot parts are not touched accidentally. The recommended installation height of the Advantage is 2.3m to 2.5m (90"-98") from the floor and under no circumstances is it to be installed at less than 2.3m from the floor. In all cases it should be installed at a height where it cannot be touched in operation. Consideration should be given to any temporary or occasional additions such as stages or platforms, and the height should be adjusted accordingly.

The Herschel Advantage IR should be firmly and permanently attached to the wall using the bracket supplied, with the heaters angled down at 60 degrees from vertical. The Herschel IR must not be attached so as to face or be close to any combustible material (eg, wood or PVC cladding, fascia or soffit).

## EXTERIOR USE

The unit is protected against water ingress (protection level IPX4), however it is recommended that the unit is installed in a covered outdoor area to give maximum protection and longevity against the effects of driving rain, wind, frost, salt and water contaminations, etc.

The canopy/roof/cover must be of a permanent nature, there must be a minimum clearance of 0.3m (12") between the cover and any part of the Herschel Advantage IR and the cover must extend a minimum of 2m (79") from the wall.

## WARRANTY

The Herschel Advantage IR is guaranteed against failure due to faulty materials or workmanship for five years from date of purchase. In the unlikely event of failure of the unit within this time, the unit must be returned to the supplier for repair or replacement. The Herschel Advantage IR contains no customer-maintainable parts.

The guarantee is invalid if the correct instructions have not been adhered to.

## MAINTENANCE

The Herschel Advantage IR is maintenance free but to maintain appearance it should occasionally be cleaned all over with a soft dry cloth. No abrasive cloths or cleaners should be used and appliances such as pressure washers, steam cleaners, etc, should never be used.

Cleaning should only be done when the unit is cold and switched off. All personnel cleaning and maintaining the unit must have suitable training and information to carry out the operation safely.

## IMPORTANT NOTICE TO PURCHASER

Before utilizing the product, the user should determine the suitability of the product for its intended use. HERSCHEL INFRARED LTD expressly disclaims the implied warranties and conditions of merchantability and fitness or a particular purpose. In no case shall HERSCHEL INFRARED LTD be liable under any legal theory, including but not limited to contract or strict liability, for any direct, indirect special, incidental or consequential damages resulting from product use.

Check that the mains supply is switched off, and then provide the mains supply connection to the Herschel Advantage IR using the specifications supplied earlier.

The BROWN wire is to be connected to LIVE ('L'), the BLUE wire to NEUTRAL ('N') and the GREEN/YELLOW wire to EARTH ('E'). Any exposed flexible cable is to hang DOWN (not tied up) and must have adequate clearance from the heater to prevent scorching or damaging the cable.





TABLE 1	1.95 kW System	
Rated Voltage (V)	115	230
Rated Current (A)	17.0	8.5
Fuse/Circuit Breaker Rating (A)	25	16

TABLE 2	1.95 kW System
Heated Zone	10-15m <sup>2</sup>
<i>This area heated figure is based on a mounting height of 2.3 - 2.5m</i>	

RATED POWER	PART NO.	ELEMENTS	FRAME
1.95 kW (3 x 650 W)	IR360-1950W	Three white glazed ceramic elements	Stainless steel body

### INSTALLATION AND OPERATING INSTRUCTIONS

Heating large indoor spaces is both a necessity and a challenge – and in certain circumstances a legal requirement. The low operating cost, large heat area and high reliability of the Herschel Advantage IR360 is why industrial units and workshops around the world are turning to the Herschel Advantage IR360 as the system of choice for reliable, cost-effective and failsafe indoor heating.

The Herschel Advantage IR360 consists of 3 highly emissive ceramic heating elements mounted in a directional, reflective unit. It is designed to gently warm people in large indoor spaces using infrared heat.

Infrared heat is a 100% natural radiating heat that humans readily absorb, producing a feeling of great comfort and well-being. Infrared Heat produced from the Herschel Advantage IR360 warms you directly without heating the air in between meaning; meaning the heat goes where you want it to and doesn't just convect upwards to heat the ceiling. No wonder customers immediately warm to Herschel Advantage IR360.

The system is easy to install; extremely discreet, produces no red glow and requires next to no maintenance. The heater will directly warm people within the lower range of the Heated Zone (note: air movement may reduce area coverage). Within enclosed areas the thermal mass of the building will also be heated within the entire zone. Dependent upon the property age/type, insulation levels, number of heaters used and running time this will increase the ambient temperatures. For larger commercial projects or where different mounting heights are required we would always recommend Herschel carry out a survey or detailed desktop assessment.

### DIAGRAM 1

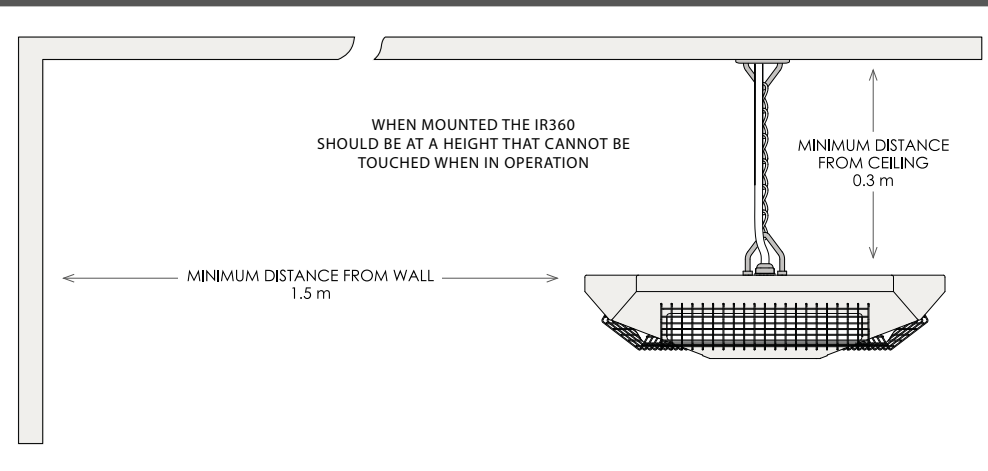

### IMPORTANT

The heating elements reach very high temperatures without visible signs of the unit being on. The heaters are not for domestic or household use. The heaters must not be used or installed in any commercial premises where they can be accidentally touched or where there is a risk of damage to the ceramic elements.

In areas with air movement/wind the directional Far Infrared spread may reduce by 1/3 to 1/2. In these areas we recommend mounting at the lowest height and proportionally increasing the number of heaters.

The Herschel Advantage IR rises to very high temperatures in use and the unit (in particular the heater elements) must not be touched when power is applied.

Do not touch the unit when it is on. After switch off the elements remain hot for a considerable time and the unit should not be touched for a minimum of 30 minutes. NEVER use the heater to ignite materials.

Ensure supply voltage does not exceed 245 volts. Note: The IR360 is not approved for exterior use.

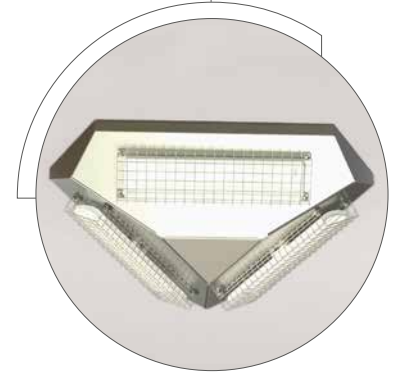

- 3 Ceramicx FTE Ceramic Elements
- Grill Protected
- Panel Size 450x 450 x 110mm - 4.4kg
- Aluminised steel reflectors
- Heating Up Time - 5 Minutes
- Useful Wavelength Range 2 -10 µm
- IP rating: IP20

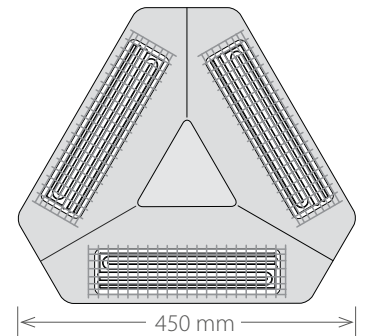

For Commercial Use Only  
Installed ceramic heaters are  
UL recognised (file no. E214574)





TABLE 1	2.6 kW System	
Rated Voltage (V)	115	230
Rated Current (A)	22.6	11.3
Fuse/Circuit Breaker Rating (A)	32	16

TABLE 2	2.6 kW System
Heated Zone	12-21m <sup>2</sup>
<i>This area heated figure is based on a mounting height of 2.8m.</i>	

RATED POWER	PART NO.	ELEMENTS	FRAME
2.6 kW (4 x 650 W)	HT-2600W	Four white FTE ceramic elements	Stainless steel body

## INSTALLATION AND OPERATING INSTRUCTIONS

The Herschel IRP4 is revolutionising the industrial heating market. It is competitively priced, easy to install and maintenance free.

The Herschel IRP4 consists of 4 highly emissive ceramic heating elements mounted in a directional, reflective unit. It provides effective zone heating in large indoor spaces using infrared heat.

Infrared Heat is a 100% natural radiating heat that humans easily absorb, producing a feeling of great comfort and well-being. Infrared Heat produced from the IRP4 warms you directly without heating the air in between; meaning the heat goes where you want it to and doesn't just convect upwards to heat the ceiling.

The heater will directly warm people within the lower range of the Heated Zone (note: air movement may reduce area coverage). Within enclosed areas the thermal mass of the building will also be heated within the entire zone. Dependent upon the property age/type, insulation levels, number of heaters used and running times this will increase the ambient temperatures. For larger commercial projects or where different mounting heights are required we would always recommend Herschel carry out a survey or detailed desktop assessment.

## DIAGRAM 1

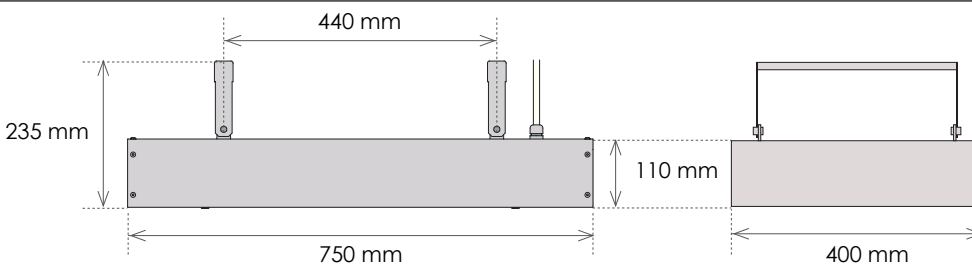
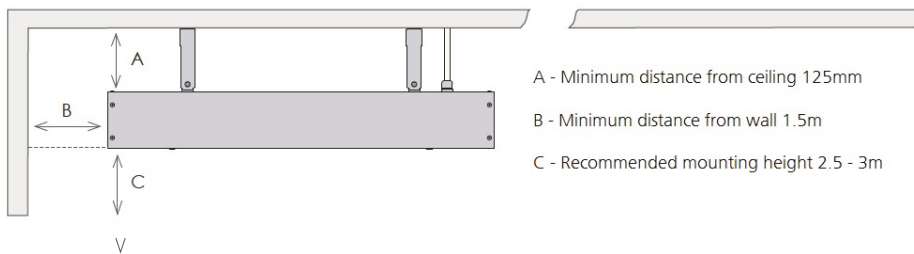

## IMPORTANT

In areas with air movement/wind the directional Far Infrared spread may reduce by 1/3 to 1/2. In these areas we recommend mounting at the lowest height and proportionally increasing the number of heaters.

The Herschel IRP4 rises to very high temperatures in use and the unit (in particular the heater elements) must not be touched when power is applied.

Do not touch the unit when it is on. After switch off the elements remain hot for a considerable time and the unit should not be touched for a minimum of 30 minutes. NEVER use the heater to ignite materials. Ensure supply voltage does not exceed 245 volts.



- 4 Ceramicx FTE Ceramic Elements
- Grill Protected
- Element Colour White
- Stainless Steel Body
- Aluminised steel reflectors
- Panel Size 750 x 400x 110 mm -11.3kg
- Heating Up Time < 5 Minutes
- Useful Wavelength Range 2 - 10 µm
- IP rating: IP20

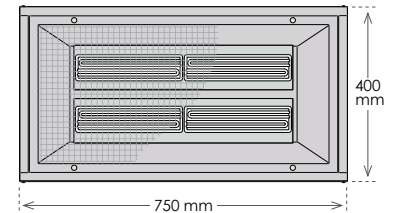



## IMPORTANT INFORMATION

Please read the following information fully, as safe and reliable operation depends on correct installation. Please keep this instruction sheet for future reference.

The AC mains supply is dangerous and potentially lethal. Ensure the mains supply is switched off at the consumer unit (fuse box) before attempting any work on electrical circuits. Wiring to this unit must be connected in accordance with the relevant national electrical safety standards. This unit must only be installed by a competent and qualified electrician. This appliance must be earthed.

## ELECTRICAL INFORMATION

The electrical supply to the unit should be provided by connecting to a circuit, which is protected by a fuse or miniature circuit breaker suitable for the electrical rating of the unit and in accordance with Table 1.

The supply to the Herschel IR must be separately switched. Alternatively a switched fused spur taken from a ring main can be used. The spur fuse should also be rated in accordance with the appropriate table. In either case the switch used to operate the Herschel IR must be indoors and readily accessible.

The cable used to connect to the existing wiring should be correctly rated solid core wiring cable. Please note that the use of flexible appliance cable with stranded conductors for permanent wiring (except for the final connection between a cable outlet and the fixed equipment) is prohibited by IEE wiring regulations. Where applicable, these regulations preclude the use of a 13A plug and socket for powering the Herschel IR. For the final connection to the Herschel IRP4, only the flexible cable and cable entry supplied with the unit must be used. The cable must connect to the supply in a suitable enclosure or cable outlet designed for that purpose. The cable outlet current carrying capacity must be greater than the recommended fuse current rating given in Table 1.

Suitable conduit or mechanical protection must be used through the wall to protect the cable from the mechanical damage within the wall. The mounting position of the unit must ensure that any mechanical damage to the flexible cable is unlikely. If physical damage to the cable is possible, suitable conduit protection must be provided.

## MOUNTING POSITION ( see Diagram 1 )

The IRP4 must be located in a position to allow proper and efficient use but one that ensures hot parts are not touched accidentally. The recommended installation height of the IRP4 is 2.5m to 3m (98"-118") from the floor and under no circumstances is it to be installed at less than 1.8m (71") from the floor. In all cases it should be installed at a height where it cannot be touched in operation.

Consideration should be given to any temporary or occasional additions such as stages or platforms, and the height should be adjusted accordingly.

The Herschel IRP4 should be firmly and permanently attached using the brackets provided with a minimum clearance of 125mm (4.9") between the top surface of the heater and the ceiling. Brackets must be attached to a solid surface capable of supporting the weight of the heater (11.3kg).

Install the heater so the supplied mains cable cannot contact the top surface of the heater during operation.

The BROWN wire is to be connected to LIVE ('L'), the blue wire to NEUTRAL ('N') and the GREEN/YELLOW wire to EARTH ('E').

The unit is IP protected up to protection level IP20.

## EXTERIOR USE

It is not approved for exterior use.

## WARRANTY

The Herschel IRP4 is guaranteed against failure due to faulty materials or workmanship for five years from date of purchase. In the unlikely event of failure of the unit within this time, the unit must be returned to the supplier for repair or replacement.

The Herschel IRP4 contains no customer usable parts. The guarantee is invalid if the correct installation instructions have not been adhered to.

## MAINTENANCE

The Herschel IR is maintenance free but to maintain appearance it should occasionally be cleaned all over with a soft dry cloth. No abrasive cloths or cleaners should be used and appliances such as pressure washers, steam cleaners, etc, should never be used.

Cleaning should only be done when the unit is cold and switched off. All personnel cleaning and maintaining the unit must have suitable training and information to carry out the operation safely.

## IMPORTANT NOTICE TO PURCHASER

Before utilizing the product, user should determine the suitability of the product for its intended use. HERSCHEL INFRARED LTD expressly disclaims the implied warranties and conditions of merchantability and fitness or a particular purpose. In no case shall HERSCHEL INFRARED LTD be liable under any legal theory, including but not limited to contract or strict liability, for any direct, indirect special, incidental or consequential damages resulting from product use.

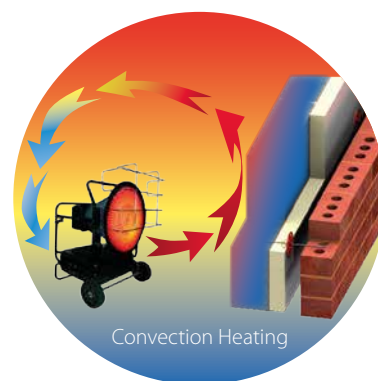

Conventional Convection Heating only heats the air within the building so the inner wall absorbs none of the heat being produced. This in turn means the walls are acting as 'cold radiators' which then very rapidly cool the air within the room once the heating system stops working.



TABLE 1	2.40 kW System	1.80 kW System
Rated Voltage (V)	230	230
Rated Current (A)	11.4	7.5
Fuse/Circuit Breaker Rating (A)	16	10

RATED POWER	PART NO.	ELEMENTS	FRAME
2.40 kW (4 x 600 W)	IRPULSAR-2400B	Four white glazed ceramic elements	Black coated mild steel body
1.80 kW (4 x 450 W)	IRPULSAR-1800W	Four white glazed ceramic elements	White coated mild steel body

### INSTALLATION AND OPERATING INSTRUCTIONS

The Pulsar is a ceiling-mounted infrared heating unit designed for high ceiling installations/large spaces in constant use. Its striking appearance and heat efficiency make Pulsar ideal for commercial areas, shops, showrooms, sports facilities and public halls where effective, efficient heat is required, but where design is important too.

When installed in combination with modern control systems that turn the heating on just before it is required and off when you leave (or actually just before) Pulsar has successfully delivered significant cost-savings to clients compared with their existing systems (please enquire for case studies).

Each Pulsar unit produces effective, comfortable levels of heat for very low wattage. Due to the perfect radiant properties of the Pulsar design and the low wattage required by the ceramic elements to raise the surface temperature of the unit to 200°C the 1800w white Pulsar will heat a zone of 8-15m<sup>2</sup> from a height of 2.5m whilst the 2400w black Pulsar will heat a zone of 12-20m<sup>2</sup> from a height of 2.8m.

The heater will directly warm people within the lower range of the Heated Zone (note: air movement may reduce area coverage). Within enclosed areas the thermal mass of the building will also be heated within the entire zone. Dependent upon the property age/type, insulation levels, number of heaters used and running times this will increase the ambient temperatures. For larger or commercial projects or where different mounting heights are required we would always recommend Herschel carry out a survey or detailed desktop assessment.

### TECHNICAL DRAWING

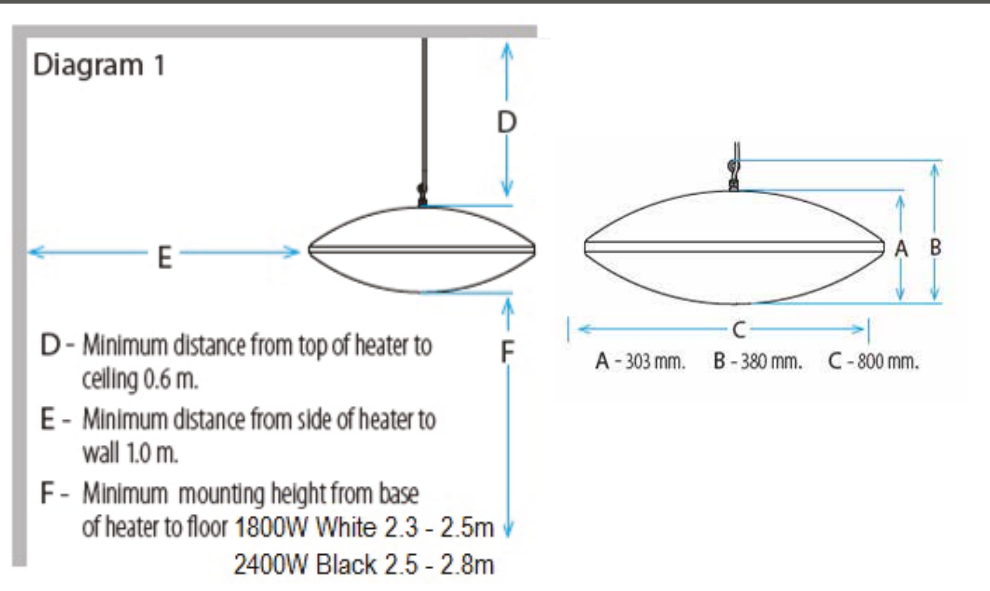

### IMPORTANT

In areas with air movement/wind the directional Far Infrared spread may reduce by 1/3 to 1/2. In these areas we recommend mounting at the lowest height and proportionally increasing the number of heaters.

The Herschel Pulsar rises to very high temperatures in use and the unit (in particular the heater elements) must not be touched when power is applied. Do not place the emitting surface closer than 1m to any object or wall and sides and top no closer than 600mm from any surface or wall. Do not touch the heater when it is on.

After switch off the elements remain hot for a considerable time and the unit should not be touched for a minimum of 30 minutes. NEVER use the heater to ignite materials. Ensure supply voltage does not exceed 245 volts.

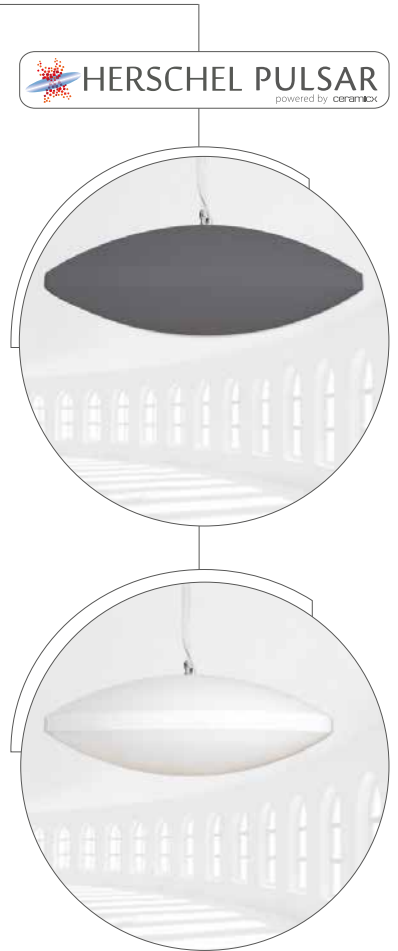

4 Ceramicx FTE Ceramic Elements  
Unit size 303 x 380 x 800 mm - 28kg  
Coated mild steel housing  
IP rating: IP20





## IMPORTANT INFORMATION

Please read the following information fully, as safe and reliable operation depends on correct installation. Please keep this instruction sheet for future reference.

The AC mains supply is dangerous and potentially lethal. Ensure the mains supply is switched off at the consumer unit (fuse box) before attempting any work on electrical circuits. Wiring to this unit must be connected in accordance with the relevant national electrical safety standards. This unit must only be installed by a competent and qualified electrician. This appliance must be earthed.

## ELECTRICAL INFORMATION

The electrical supply to the unit should be provided by connecting to a circuit, which is protected by a fuse or miniature circuit breaker suitable for the electrical rating of the unit and in accordance with Table 1.

The power supply to the Herschel Pulsar must not exceed 245 volts, as this will void the warranty.

The supply to the Herschel Pulsar must be separately switched. Alternatively, a switched fused spur taken from a ring main can be used. The spur fuse should also be rated in accordance with the table. In either case the switch used to operate the Herschel Pulsar must be indoors and readily accessible.

The cable used to connect to the existing wiring should be correctly rated solid core wiring cable. Please note that the use of flexible appliance cable with stranded conductors for permanent wiring (except for the final connection between a cable outlet and the fixed equipment) is prohibited by IEE wiring regulations. Where applicable, these regulations preclude the use of a 13A plug and socket for powering the Herschel IR. For the final connection to the Herschel IRP4, only the flexible cable and cable entry supplied with the unit must be used. The cable must connect to the supply in a suitable enclosure or cable outlet designed for that purpose. The cable outlet current carrying capacity must be greater than the recommended fuse current rating given in Table 1.

Suitable conduit or mechanical protection must be used through the wall to protect the cable from mechanical damage within the wall. The mounting position of the unit must ensure that any mechanical damage to the flexible cable is unlikely. If physical damage to the cable is possible, suitable conduit protection must be provided.

## OPERATIONAL POSITION

The Herschel Pulsar must be located in a position to allow proper and efficient use but one that ensures hot parts are not touched accidentally.

The recommended installation height of the White 1800W Pulsar is 2.3m – 2.5m (90" – 98") from the floor. The recommended installation height of the Black 2400W Pulsar is 2.5-2.8m (98"-110") from the floor.

Under no circumstances is either unit to be installed at less than 1.8m (71") from the floor.

In all cases it should be installed at a height where it cannot be touched in operation. Consideration should be given to any temporary or occasional additions such as stages or platforms, and the height should be adjusted accordingly. The Herschel Pulsar should be firmly and permanently attached to a solid surface with a minimum clearance of 0.60m (23.6") between the top surface of the heater and the ceiling.

Fixing must be effected by a mounting plate and support chain or wire capable of carrying up to 112kg (equal to 4x the weight of the Pulsar).

Install the heater so the supplied mains cable cannot contact the top surface of the heater during operation.

The BROWN wire is to be connected to LIVE ('L'), the BLUE wire to NEUTRAL ('N') and the GREEN/YELLOW wire to EARTH ('E').

The unit is IP protected to protection level IP20.

## EXTERIOR USE

It is not approved for exterior use.

## WARRANTY

The Herschel Pulsar is guaranteed against failure due to faulty materials or workmanship for five years from date of purchase. In the unlikely event of failure of the unit within this time, the unit must be returned to the supplier for repair or replacement.

The Herschel Pulsar contains no customer usable parts. The guarantee is invalid if the correct installation instructions have not been adhered to.

## MAINTENANCE

The Herschel Pulsar is maintenance free but to maintain appearance it should occasionally be cleaned all over with a soft dry cloth. No abrasive cloths or cleaners should be used and appliances such as pressure washers, steam cleaners etc., should never be used. Cleaning should only be done when the unit is cold and switched off. All personnel cleaning and maintaining the unit must have suitable training and information to carry out the operation safely.

## IMPORTANT NOTICE TO PURCHASER

Before utilizing the product, user should determine the suitability of the product for its intended use. HERSCHEL INFRARED LTD expressly disclaims the implied warranties and conditions of merchantability and fitness or a particular purpose. In no case shall HERSCHEL INFRARED LTD be liable under any legal theory, including but not limited to contract or strict liability, for any direct, indirect special, incidental or consequential damages resulting from product use.



# PANEL HEATING RANGE

Ultra-slim, stylish heaters  
for rooms and domestic  
environments





The most cost-effective and efficient frameless far infrared panel heater on the market, the new Select XL from Herschel is ideally suited to the commercial sector including hotels, new homes, student accommodation and rental properties.

The new frameless Select XL range is available in 250 W through to 1000 W and employs the latest, newly developed Herschel heating element which is up to 10% more effective than competitor products.

With a high quality aluminium casing, the Select XL features Herschel's new and innovative easy-fix bracket. No other system is as simple to install and as secure once mounted. The discreet, ultra slim, white panels are designed for ceiling or wall-mounting and will complement any interior. They are TUV approved, have an IP44 rating and come complete with a five year warranty

The heated areas are a guide only and assume a medium to well insulated space with an average floor to ceiling height of 2.40M. If room heights are greater or there are other building factors to consider then please fill out the quote form under the Customer Service section of the Herschel website or contact your dealer directly so that a more detailed assessment can be carried out.

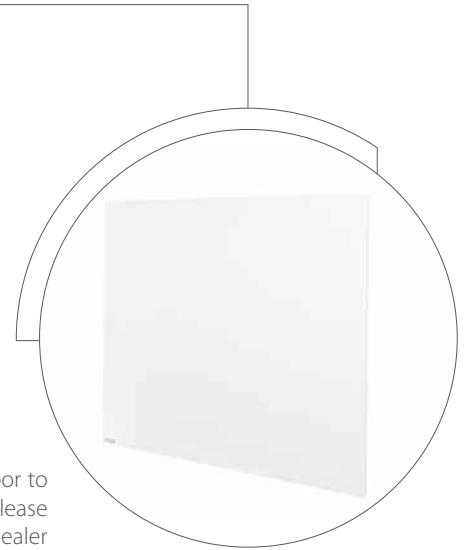

TECHNICAL DETAILS

- SURFACE: Aluminium
- COLOUR: White
- HEATING ELEMENT: Herschel COSIX® Cell Technology
- REAR PANEL: Aluminium with Herschel EASY-FIX system
- FRAME: Frameless
- SURFACE TEMPERATURE: App. 85° C - 95° C
- VOLTAGE: 220-240 V, 50/60 Hz
- PROTECTION CLASS: IP 44
- CABLE: 2.5 m power cable with fitted plug
- INSTALLATION: Wall or ceiling mounted  
\*For ceiling mounting, use suitable fixings or connect to ceiling joist to secure the heaters safely.

CERTIFICATES:



WARRANTY:

5-years

AVAILABLE MODELS

Model	Part No.	Dimensions	Weight	Rated Power	Heated Area
<b>SELECT XL WHITE</b>	XL-HS250-W	30 x 90 cm	4,7 kg	250 W	4 - 6m <sup>2</sup>
	XL-HS300-W	59,5 x 59,5 cm	5,7 kg	300 W	5 - 7m <sup>2</sup>
	XL-HS600-W	65 x 100 cm	11,3 kg	600 W	11 - 13m <sup>2</sup>
	XL-HS850-W <i>(ceiling only)</i>	85 x 120 cm	16,3 kg	850 W Ceiling only	14 - 21m <sup>2</sup>
	XL-HS1000-W <i>(wall only)</i>	85 x 120 cm	16,3 kg	1000 W Wall only	15 - 21m <sup>2</sup>

SIGNIFICANT ENERGY SAVINGS

Far Infrared heating panels offer owners an unprecedented level of control over their property's temperature and energy use.

Installations using our panels optimally zoned and controlled can save between 30 – 60% of the energy consumption of traditional solutions including gas, oil and other electrical solutions.

UP TO **60%** IMPROVED HEAT EFFICIENCY



NO WASTED ENERGY MEANS EXACTLY THAT **100%** OF THE ELECTRICAL ENERGY USED BY THE HEATING SYSTEM IS CONVERTED INTO HEAT



The Herschel **SELECT XL Glass** panel heater forms part of our high performance **Select XL** range. It is ideally suited to both the commercial and domestic sector including new homes, hotels and any environment where stylish looks are important. Select XL Glass units are especially popular in bathrooms and kitchens. For bathrooms, an optional high quality stainless steel towel rail can be added for warming towels as well as heating your bathroom. All units combine higher energy efficiency with an improved level of heating comfort compared with other heating systems.

The **Select XL Glass** is available in two sizes with a black or white glass finish. Available wattage is 500 or 700 Watt units giving a heated area of 9-12 and 13-15m<sup>2</sup> respectively.

All units use Herschel COSIX® Cell Technology and have an aluminium rear case incorporating Herschel's EASY-FIX mounting system. The front emitting surface is safety glass.

The heated areas are a guide only and assume a medium to well insulated space with an average floor to ceiling height of 2.40M. If room heights are greater or there are other building factors to consider then please fill out the quote form under the Customer Service section of the Herschel website or contact your dealer directly so that a more detailed assessment can be carried out.

TECHNICAL DETAILS

- SURFACE: ESG 6mm Safety Glass
- COLOUR: White or Black
- HEATING ELEMENT: Herschel COSIX® Cell Technology
- REAR PANEL: Aluminium with Herschel EASY-FIX System
- FRAME: Frameless
- SURFACE TEMPERATURE: App. 85° C - 95° C
- VOLTAGE: 220-240 V, 50/60 Hz
- PROTECTION CLASS: IP 45
- CABLE: 2.5 m power cable with fitted plug
- INSTALLATION: Wall-mounted
- CERTIFICATES:
- WARRANTY: 5-years

AVAILABLE MODELS

Model	Part No.	Dimensions	Weight	Rated Power	Heated Area
<b>SELECT XL GLASS</b>	HS500-GW	60 x 100 x 2,5 cm	14,5 kg	500 W	9 - 12 m <sup>2</sup>
	HS500-GB	60 x 100 x 2,5 cm	14,5 kg	500 W	9 - 12 m <sup>2</sup>
	HS700-GW	70 x 130 x 2,5 cm	22,3 kg	700 W	13 - 15 m <sup>2</sup>
	HS700-GB	70 x 130 x 2,5 cm	22,3 kg	700 W	13 - 15 m <sup>2</sup>

SIGNIFICANT ENERGY SAVINGS

Herschel Far Infrared heating panels offer owners an unprecedented level of control over their property's temperature and energy use and offer higher thermal comfort levels. Installations using Herschel panels, optimally zoned and controlled, can save between 30 – 60% of the energy consumption of other electric heating solutions including night storage, digital convection heaters and electric underfloor heating, as well as the lowest total cost of ownership.

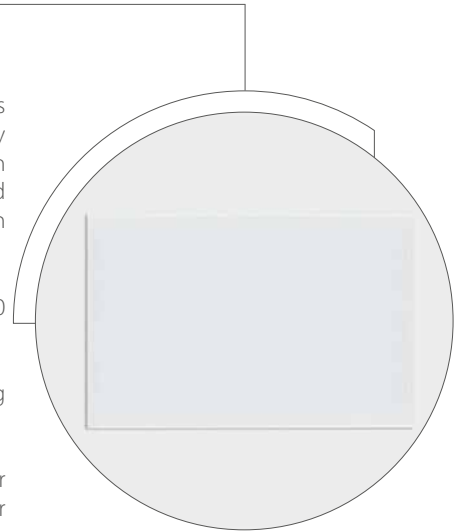

UP TO **60%** IMPROVED HEAT EFFICIENCY

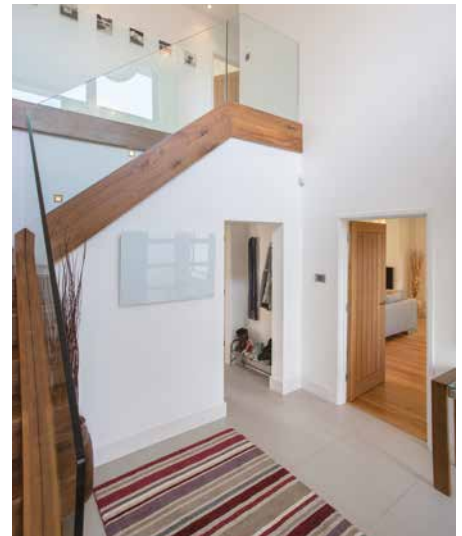

NO WASTED ENERGY MEANS EXACTLY THAT **100%** OF THE ELECTRICAL ENERGY USED BY THE HEATING SYSTEM IS CONVERTED INTO HEAT



The Herschel **Select XL Mirror** forms part of our high performance Select XL range. It is ideally suited to both the commercial and domestic sector.

**Select XL Mirror** can be placed in humid areas such as bathrooms without any condensation forming on the glass, whilst also chasing away the causes of moisture that convection-based heaters actually encourage (hot air moving over a cold surface). Due to the infrared heating process, **Select XL** heats up objects in the room rather than the air. This helps to keep walls and furniture in humid areas warm, dry and free of mould.

In addition to being a stylish, energy-efficient addition to bathrooms, **Select XL mirrors** are popular for hallways, bedrooms and living rooms.

All units are made with Mirrored Safety Glass and manufactured from the highest quality materials under strict quality control and incorporate Herschel's COSIX® cell heating technology and innovative EASY-FIX mounting system.

The heated areas are a guide only and assume a medium to well insulated space with an average floor to ceiling height of 2.40M. If room heights are greater or there are other building factors to consider then please fill out the quote form under the Customer Service section of the Herschel website or contact your dealer directly so that a more detailed assessment can be carried out.

TECHNICAL DETAILS

SURFACE:	ESG Glass with reflective Mirror coating
COLOUR:	N/A
HEATING ELEMENT:	Herschel COSIX® Cell Technology
REAR PANEL:	Aluminium with Herschel EASY-FIX System
FRAME:	Frameless
SURFACE TEMPERATURE:	App. 85° C - 95° C
VOLTAGE:	220-240 V, 50/60 Hz
PROTECTION CLASS:	IP 45
CABLE:	2.5 m power cable with fitted plug
INSTALLATION:	Wall-mounted
CERTIFICATES:	    
WARRANTY:	5-years

AVAILABLE MODELS

Model	Part No.	Dimensions	Weight	Rated Power	Heated Area
<b>SELECT XL MIRROR</b>	HS350-M	66 x 66 x 2,5 cm	10,5 kg	350 W	6 - 8 m <sup>2</sup>
	HS500-M	60 x 100 x 2,5 cm	14,5 kg	500 W	9 - 12 m <sup>2</sup>
	HS700-M	70 x 130 x 2,5 cm	22,3 kg	700 W	13 - 15 m <sup>2</sup>

SIGNIFICANT ENERGY SAVINGS

Herschel Far Infrared heating panels offer owners an unprecedented level of control over their property's temperature and energy use and offer higher thermal comfort levels. Installations using Herschel panels, optimally zoned and controlled, can save between 30 – 60% of the energy consumption of other electric heating solutions including night storage, digital convection heaters and electric underfloor heating, as well as the lowest total cost of ownership.



UP TO **60%** IMPROVED HEAT EFFICIENCY



NO WASTED ENERGY MEANS EXACTLY THAT **100%** OF THE ELECTRICAL ENERGY USED BY THE HEATING SYSTEM IS CONVERTED INTO HEAT





The all new **SELECT WHITE** range offers true affordable value, ideal for applications that require a lower cost solution but with all the benefits of Far Infrared heating.

The **SELECT WHITE** Far Infrared heater has a white frame and is flush fitting to the wall or ceiling.

The heater is available in 3 different sizes, can be wall or ceiling mounted (making it ideal for passageways and office ceilings) and is available in stand-alone operation by using special feet (sold separately).

The **SELECT WHITE** is lightweight and the HS350-W and HS700-W are also ideal for use in office ceiling grids.

**SELECT WHITE** Far Infrared heaters- Snap-on feet for free-standing operation.

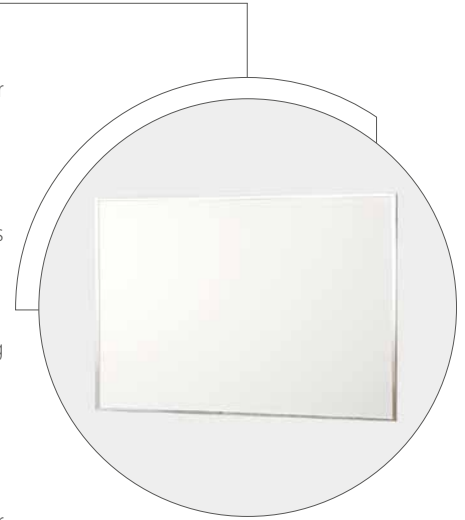
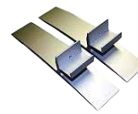

The heated areas are a guide only and assume a medium to well insulated space with an average floor to ceiling height of 2.40M. If room heights are greater or there are other building factors to consider then please fill out the quote form under the Customer Service section of the Herschel website or contact your dealer directly so that a more detailed assessment can be carried out.

### TECHNICAL DETAILS

SURFACE:	Aluminium
COLOUR:	White
HEATING ELEMENT:	Herschel COSIX® Cell Technology
REAR PANEL:	Steel with Herschel EASY-FIX System
FRAME:	White powder coated aluminium frame
SURFACE TEMPERATURE:	App. 85° C - 95° C
VOLTAGE:	220-240 V, 50/60 Hz
PROTECTION CLASS:	IP 44
CABLE:	2.5 m power cable with fitted plug
INSTALLATION:	Wall or ceiling mounted <small>*For ceiling mounting, use suitable fixings or connect to ceiling joist to secure the heaters safely</small>
CERTIFICATES:	     
WARRANTY:	5-years

UP TO **60%** IMPROVED HEAT EFFICIENCY



### AVAILABLE MODELS

Model	Part No.	Dimensions	Weight	Rated Power	Heated Area
<b>SELECT WHITE</b>	HS350-W	59,5 x 59,5 x 2,5 cm	5,2kg	350 W	6 - 8m <sup>2</sup>
	HS540-W	60 x 90 x 2,5 cm	7,2 kg	540 W	9 - 12m <sup>2</sup>
	HS700-W	59,5 x 119,5 x 2,5 cm	9,2 kg	700 W	13 - 15m <sup>2</sup>

### SIGNIFICANT ENERGY SAVINGS

Far Infrared heating panels offer owners an unprecedented level of control over their property's temperature and energy use.

Installations using our panels optimally zoned and controlled can save between 30 – 60% of the energy consumption of traditional solutions including gas, oil and other electrical solutions.

NO WASTED ENERGY MEANS EXACTLY THAT **100%** OF THE ELECTRICAL ENERGY USED BY THE HEATING SYSTEM IS CONVERTED INTO HEAT



**SELECT INTEGRATED CEILING** Far Infrared heating panels are designed to fit discreetly into commercial ceiling grids, making them suitable for new buildings or reconstruction projects in offices, schools and other public places.



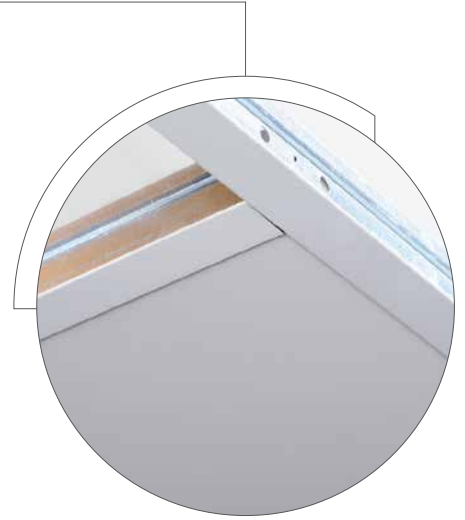

The **SELECT INTEGRATED CEILING** panels allow full usage of wall and floor space. They are simple and easy to install and easy to control room by room without wasting energy needlessly heating unoccupied spaces.

**SELECT INTEGRATED CEILING** units are made from the highest quality materials and combine high efficiency with an improved level of comfort heating.

The heated areas are a guide only and assume a medium to well insulated space with an average floor to ceiling height of 2.40M. If room heights are greater or there are other building factors to consider then please fill out the quote form under the Customer Service section of the Herschel website or contact your dealer directly so that a more detailed assessment can be carried out.



## TECHNICAL DETAILS

SURFACE:	Aluminium
COLOUR:	White
HEATING ELEMENT:	Herschel COSIX® Cell Technology
REAR PANEL:	Steel with Herschel EASY-FIX System
FRAME:	White powder coated aluminium frame
SURFACE TEMPERATURE:	App. 85° C - 95° C
VOLTAGE:	220-240 V, 50/60 Hz
PROTECTION CLASS:	IP 44
CABLE:	2.5 m power cable with fitted plug
INSTALLATION:	Ceiling integrated
CERTIFICATES:	    
WARRANTY:	5-years

UP TO **60%** IMPROVED HEAT EFFICIENCY

## AVAILABLE MODELS

Model	Part No.	Dimensions	Weight	Rated Power	Heated Area
<b>SELECT WHITE</b>	HS350-W	59,5 x 59,5 x 2,5 cm	5,2kg	350 W	6 - 8m <sup>2</sup>
	HS700-W	59,5 x 119,5 x 2,5 cm	9,2kg	700 W	13 - 15m <sup>2</sup>

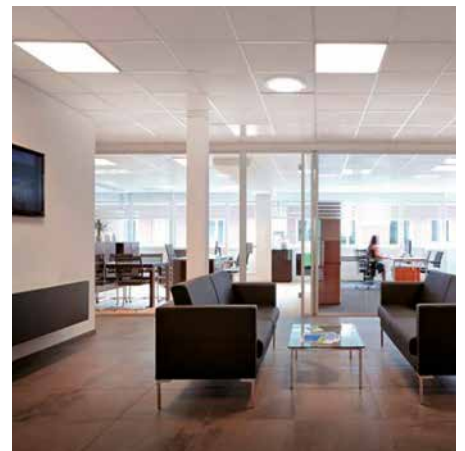

## SIGNIFICANT ENERGY SAVINGS

Far Infrared heating panels offer owners an unprecedented level of control over their property's temperature and energy use.

Installations using our panels optimally zoned and controlled can save between 30 – 60% of the energy consumption of traditional solutions including gas, oil and other electrical solutions.

NO WASTED ENERGY MEANS EXACTLY THAT **100%** OF THE ELECTRICAL ENERGY USED BY THE HEATING SYSTEM IS CONVERTED INTO HEAT



**INSPIRE WHITE** Far Infrared heaters operate at a fraction of the cost of traditional heating but offer higher thermal comfort levels.

The **INSPIRE WHITE** Far Infrared heaters are energy efficient and a great space-saving heating solution made from high-quality materials.

This range of heating panels is designed to complement any environment, and are suitable for both domestic and commercial installations.

The heated areas are a guide only and assume a medium to well insulated space with an average floor to ceiling height of 2.40M. If room heights are greater or there are other building factors to consider then please fill out the quote form under the Customer Service section of the Herschel website or contact your dealer directly so that a more detailed assessment can be carried out.

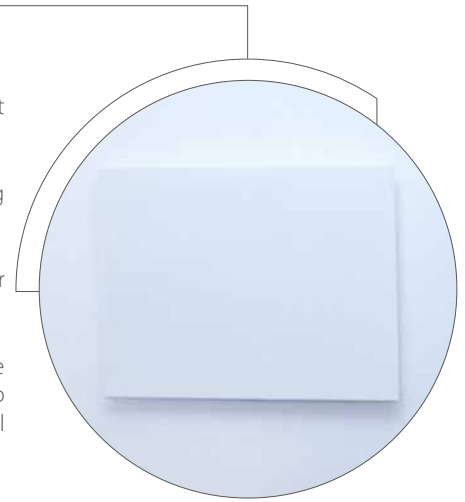

## TECHNICAL DETAILS

SURFACE:	Aluminium, powder coated
COLOUR:	White
REAR PANEL:	Sheet steel, powder-coated, mounting points
FRAME:	Frameless
SURFACE TEMPERATURE:	App. 85° C - 95° C
VOLTAGE:	230 V, 50 Hz
PROTECTION CLASS:	IP 54
INSTALLATION:	Wall or ceiling mounted <small>*For ceiling mounting, use suitable fixings or connect to ceiling joist to secure the heaters safely.</small>
CERTIFICATES:	     
WARRANTY:	10 -years

UP TO **60%** IMPROVED HEAT EFFICIENCY

## AVAILABLE MODELS

Model	Part No.	Dimensions	Weight	Rated Power	Heated Area
INSPIRE WHITE	CL-200	60 x 30 cm	3,5 kg	250 W	3 - 5 m <sup>2</sup>
	CL-300	90 x 30 cm	5,0 kg	350 W	4 - 7 m <sup>2</sup>
	CL-400	60 x 60 cm	6,0 kg	420 W	5 - 8 m <sup>2</sup>
	CL-500	80 x 60 cm	8,0 kg	550 W	7 - 12 m <sup>2</sup>
	CL-750	90 x 70 cm	9,8 kg	750 W	11 - 18 m <sup>2</sup>
	CL-750L	170 x 40 cm	9,8 kg	820 W	11 - 18 m <sup>2</sup>
	CL-900	100 x 80 cm	12,0 kg	900 W	13 - 22 m <sup>2</sup>
	CL-1200	120 x 80 cm	15,3 kg	1200 W	17 - 29 m <sup>2</sup>
	CL-1200L	160 x 60 cm	15,3 kg	1250 W	17 - 29 m <sup>2</sup>



## SIGNIFICANT ENERGY SAVINGS

Far Infrared heating panels offer owners an unprecedented level of control over their property's temperature and energy use.

Installations using our panels optimally zoned and controlled can save between 30 – 60% of the energy consumption of traditional solutions including gas, oil and other electrical solutions.

NO WASTED ENERGY MEANS EXACTLY THAT **100%** OF THE ELECTRICAL ENERGY USED BY THE HEATING SYSTEM IS CONVERTED INTO HEAT



(With frame)

**INSPIRE PICTURE** Far Infrared heating panels combine efficiency and comfort with stylish, eye-catching printed designs. Mundane and space consuming radiators become a thing of the past with the wall mounted picture panels, just like traditional pictures.

These FAR Infrared heating panels will not only heat your rooms but can also serve as aesthetic pieces of art for your home. Choose any design from our range of standard motifs, or provide your own picture or photo for printing.

The heated areas are a guide only and assume a medium to well insulated space with an average floor to ceiling height of 2.40M. If room heights are greater or there are other building factors to consider then please fill out the quote form under the Customer Service section of the Herschel website or contact your dealer directly so that a more detailed assessment can be carried out.



### TECHNICAL DETAILS

SURFACE:	ESG safety glass
COLOUR:	Printed standard or custom motifs
REAR PANEL:	Sheet steel, powder-coated, mounting points
SURFACE TEMPERATURE:	App. 85°C - 95°C
VOLTAGE:	230 V, 50 Hz
PROTECTION CLASS:	IP 54
INSTALLATION:	Wall mounted
CERTIFICATES:	
WARRANTY:	10-years

UP TO **60%** IMPROVED HEAT EFFICIENCY

### AVAILABLE MODELS

Model	Part No.	Dimensions	Weight	Rated Power	Heated Area
INSPIRE PICTURE	BH-200	60 x 30 cm	4,1 kg	250 W	3 - 5 m <sup>2</sup>
	BH-300	90 x 30 cm	6,2 kg	350 W	4 - 7 m <sup>2</sup>
	BH-400	60 x 60 cm	7,5 kg	420 W	5 - 8 m <sup>2</sup>
	BH-500	80 x 60 cm	10,1 kg	550 W	7 - 12 m <sup>2</sup>
	BH-750	90 x 70 cm	13,0 kg	750 W	11 - 18 m <sup>2</sup>
	BH-900	100 x 80 cm	16,3 kg	900 W	13 - 22 m <sup>2</sup>
	BH-1200	120 x 80 cm	20,0 kg	1200 W	17 - 29 m <sup>2</sup>



### FRAMES - available options

Model	Part No.	Product picture
INSPIRE FRAME OPTIONS	Silver matt	AP-RA 7004
	Silver shiny	AP-RA 7003
	Brushed mercury	AP-RA 7327
	Gold shiny	AP-RA 7001
	Black matt	AP-RA 7021
	Walnut structured	AP-RA 7318

Printed colors may vary from the original articles for illustrative reasons. Subject to technical changes and changes in the range and availability.

### INDIVIDUAL MOTIFS

Almost any personal motif, picture or logo with a minimum data size of 3-5 MB can be used for reproduction on our heating panels. Accepted formats for image processing are: TIF, JPG, PSD, PDF, EPS files.





**INSPIRE MIRROR** Far Infrared heating panels are an ideal addition to your bathroom, hallway, or to the reception area or lobby of a corporate building.







The **INSPIRE MIRROR** Far Infrared heating panels can be placed in humid areas without any condensation forming on the mirror glass.

Due to the Far Infrared heating process, the mirrors heat up objects in the room rather than the air itself. This helps keep walls and furniture in humid areas dry and free of mould. Walls that are already moist and prone to mould will swiftly dry out, the mould cannot return.

The heated areas are a guide only and assume a medium to well insulated space with an average floor to ceiling height of 2.40M. If room heights are greater or there are other building factors to consider then please fill out the quote form under the Customer Service section of the Herschel website or contact your dealer directly so that a more detailed assessment can be carried out.



## TECHNICAL DETAILS

SURFACE:	ESG mirror glass
COLOUR:	-
REAR PANEL:	Sheet steel, powder-coated, mounting points
SURFACE TEMPERATURE:	App. 85°C - 95°C
VOLTAGE:	230 V, 50 Hz
PROTECTION CLASS:	IP 54
INSTALLATION:	Wall mounted
CERTIFICATES:	     
WARRANTY:	10 -years

UP TO **60%** IMPROVED HEAT EFFICIENCY

## AVAILABLE MODELS

Model	Part No.	Dimensions	Weight	Rated Power	Heated Area
<b>INSPIRE MIRROR</b>	SH-200	60 x 30 cm	5,0 kg	250 W	3-5 m <sup>2</sup>
	SH-300	90 x 30 cm	7,5 kg	350 W	4-7 m <sup>2</sup>
	SH-400	60 x 60 cm	7,5 kg	420 W	5-8 m <sup>2</sup>
	SH-500	80 x 60 cm	12,5 kg	550 W	7-12 m <sup>2</sup>
	SH-750	90 x 70 cm	16,2 kg	750 W	11-18 m <sup>2</sup>
	SH-900	100 x 80 cm	20,3 kg	900 W	13-22 m <sup>2</sup>
	SH-1200L	160 x 60 cm	25,0 kg	1250 W	17-29 m <sup>2</sup>

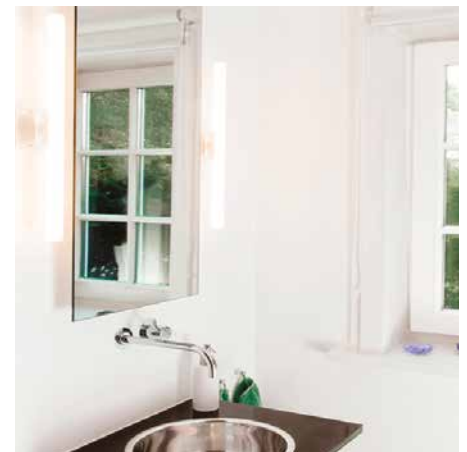

## SIGNIFICANT ENERGY SAVINGS

Far Infrared heating panels offer owners an unprecedented level of control over their property's temperature and energy use.

Installations using our panels optimally zoned and controlled can save between 30 – 60% of the energy consumption of traditional solutions including gas, oil and other electrical solutions.

NO WASTED ENERGY MEANS EXACTLY THAT **100%** OF THE ELECTRICAL ENERGY USED BY THE HEATING SYSTEM IS CONVERTED INTO HEAT



(Frameless - with frame as an option)

**INSPIRE GLASS** Far Infrared heaters are made from high-quality reinforced safety glass (ESG) combining sophisticated designs with optimum safety and energy efficiency, a system never out of style.

This sleek, beautiful design will enhance your home or office with class and elegance but also guarantee an improved level of comfort. Enjoy the benefits of Far Infrared healthy heating In your home or office.

The **INSPIRE GLASS** Far Infrared heaters come in 4 different sizes and are available in white, black & pastel green colours. A selection of optional frames is available (with surcharge).

The heated areas are a guide only and assume a medium to well insulated space with an average floor to ceiling height of 2.40M. If room heights are greater or there are other building factors to consider then please fill out the quote form under the Customer Service section of the Herschel website or contact your dealer directly so that a more detailed assessment can be carried out.



UP TO **60%** IMPROVED HEAT EFFICIENCY

### TECHNICAL DETAILS

SURFACE:	ESG safety glass
COLOUR:	White, Black, Pastel Green
REAR PANEL:	Sheet steel, powder-coated, mounting points
SURFACE TEMPERATURE:	App. 85° C - 95° C
VOLTAGE:	230 V, 50 Hz
PROTECTION CLASS:	IP 54
INSTALLATION:	Wall mounted
CERTIFICATES:	
WARRANTY:	10-years

### AVAILABLE MODELS

Model	Part No.	Dimensions	Weight	Rated Power	Heated Area
<b>INSPIRE GLASS</b>	GH-300	90 x 30 cm	7,5 kg	350 W	4 - 7 m <sup>2</sup>
	GH-500	80 x 60 cm	12,5 kg	550 W	7 - 12 m <sup>2</sup>
	GH-750	90 x 70 cm	16,2 kg	750 W	11 - 18 m <sup>2</sup>
	GH-900	100 x 80 cm	20,3 kg	900 W	13 - 22 m <sup>2</sup>



### OPTIONAL FRAMES (with surcharge)

Model	Part No.	Product picture	
<b>INSPIRE FRAME OPTIONS</b>	Silver matt	AP-RA 7004	
	Silver shiny	AP-RA 7003	
	Brushed mercury	AP-RA 7327	
	Gold shiny	AP-RA 7001	
	Black matt	AP-RA 7021	
	Walnut structured	AP-RA 7318	

Printed colours may vary from the original articles for illustrative reasons. Subject to technical changes and changes in the range and availability.

NO WASTED ENERGY MEANS EXACTLY THAT **100%** OF THE ELECTRICAL ENERGY USED BY THE HEATING SYSTEM IS CONVERTED INTO HEAT



## INTELLIGENT CONTROL

Get the most from your Herschel heaters by adding the iQ system. Starting with just one heater in one room - add as many devices as you want\* over time to get full control of your home's energy use.

\* Up to 36 R1 receivers may be added. These can control up to 2.3kw each or more heaters via relay-switched circuits.

### WH1 Central Control Unit



### R1 Receiver



+



=



## SINGLE ZONE CONTROL

Start your home control with Herschel iQ's Single Zone Pack. Intelligent temperature & time control for all heaters on a 10 amp circuit. Add a new pack for a new zone or just add another R1 Receiver to receive the same commands from the T1 Wireless Thermostat.

### T1 Wireless Thermostat



### R1 Receiver



10 amp load



## WHOLE HOUSE/ MULTIPLE ZONE CONTROL

Advance to a whole house control solution where you can control everything at the touch of a button; zone by zone or even heater by heater. The WH1 Central Control Unit allows you to add 6 zones with up to 6 R1 Receivers per zone. In this configuration, the R1 acts as the local thermostat and switch, following its own temperature control programme and switching the heaters on and off accordingly.



Manages up to 6 zones

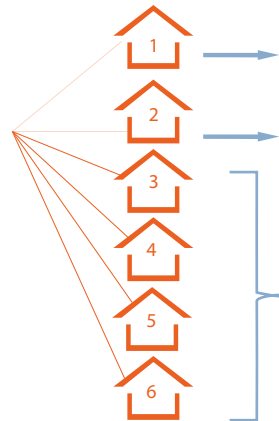

### Example



R1 used as boiler switch for existing central heating system. (Placed in location of existing thermostat).



Up to 6 R1's to control other existing electric heaters. Or zone of mixed existing + Herschel Infrared.



4 other zones with up to 24 R1's to control your new Herschel Infrared system.

**Safety:** SAFETY EN60950  
 EMC ETSI EN301489  
 RADIO ETSI EN200220  
 BS EN 60730-1: 2011  
 RoHS 2011/65 EC  
 REACH 1907/2006/EC  
 Low voltage directive IEC 60730-2-9: 2010 and IEC 60730-1: 2011  
 ISO 900q: 2008 Compliant manufacture  
 EN 6100-6-2: 2007 + A1: 2011  
 EN61000-3-2: 2014  
 EN 61000-3-3: 2013  
 EN 61000-6-1: 2007

**Complies with:** 2006/95/EC The Low Voltage Directive N/A  
 2004/108/EEC The Electromagnetic Compatibility Directive  
 2011/65/EC Restriction of Hazardous Substances  
 1999/5/EC R&TTE Directive  
 93/68/EEC CE Marking Directive

Product Dimensions (installed)	Width(cm)	Height(cm)	Depth(cm)
T1	12	8.5	2.5
R1	8.5	8.5	2.5(recessed) 3.5(surface mounted)
WH1 (recessed)	13	9	2(requires 4cm depth back box)

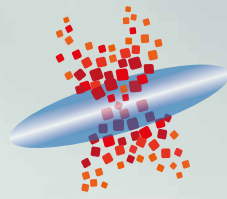

**HERSCHEL**<sup>®</sup>  
far infrared heaters



Select XL 1000W

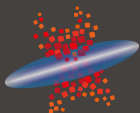

**HERSCHEL**<sup>®</sup>  
the future of heating – today

**For further information contact:**  
email: [info@herschel-infrared.com](mailto:info@herschel-infrared.com)  
[www.herschel-infrared.com](http://www.herschel-infrared.com)  
Phone: +44 (0)1473 760059

**Distributed by:**

0217

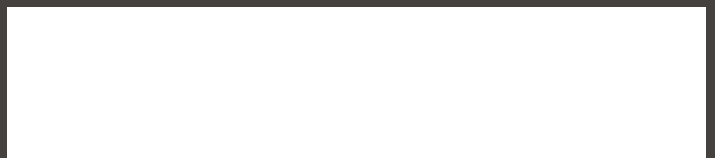

All information in this catalogue is accurate at the time of printing.